



# **MULTIMIG 200 PRO**

## **Inverter Based Welding Machines**

**IMPORTANT: Read this Owner's Manual Completely** before attempting to use this equipment. Save this manual and keep it handy for quick reference. Pay particular attention to the safety instructions we have provided for your protection. Contact your distributor if you do not fully understand this manual.

# CONTENT

<b>§1 Safety .....</b>	<b>1</b>
§1.1 Symbols Explanation .....	1
§1.2 Machine Operating warnings!.....	1
§1.3 EMC device classification.....	7
§1.4 EMC measure.....	8
§1.5 Warning label.....	9
<b>§2 Overview.....</b>	<b>10</b>
§2.1 Features .....	10
§2.2 Technical Data .....	11
§2.3 Brief Introduction.....	11
§2.4 Duty cycle and Over-heat.....	12
§2.5 Working Principle .....	13
§2.6 Volt-Ampere Characteristic .....	13
<b>§3 Panel Functions &amp; Descriptions .....</b>	<b>15</b>
§3.1 Machine Layout Description.....	15
§3.2 Layout for Control panel.....	16
§3.2.1 Control panel.....	16
§3.2.2 MMA AC/DC display introduction.....	17
§3.2.3 TIG HF/Lift display introduction .....	18
§3.2.4 MIG Manual display introduction .....	24
§3.2.5 MIG SYN display introduction .....	25
§3.2.6 JOB display introduction .....	28
<b>§4 Installation &amp; Operation .....</b>	<b>29</b>
§4.1 Installation & Operation for MMA Electrode Welding.....	29
§4.1.1 Set-Up Installation.....	29
§4.1.2 MMA/Stick Electrode Welding.....	30
§4.1.3 MMA Welding Fundamentals .....	31
§4.2 Installation & Operation for TIG Welding .....	33
§4.2.1 Set-Up for TIG Welding.....	33
§4.2.2 DCTIG Welding.....	35
§4.2.3 TIG Welding Fusion Technique.....	36
§4.2.4 Tungsten Electrodes .....	38
§4.2.5 Tungsten Preparation .....	40
§4.2.6 TIG Torch Switch Controls.....	42

<b>§4.3 Installation &amp; Operation for MIG Welding .....</b>	<b>44</b>
§4.3.1 Set up installation for MIG Welding .....	44
§4.3.2 Wire Feed Roller Selection.....	46
§4.3.3 Wire Installation and Set-Up Guide.....	47
§4.3.4 MIG Torch Liner Types and Information .....	49
§4.3.5 Torch & Wire Feed Set-Up for Aluminum Wire.....	51
§4.3.6 MIG Welding .....	51
<b>§4.4 Installation &amp; Operation for Spool Gun.....</b>	<b>58</b>
§4.4.1 Set up installation for Spool Gun .....	58
§4.4.2 Spool Gun Control.....	59
<b>§4.5 Welding Parameters .....</b>	<b>61</b>
<b>§4.6 Operation Environment.....</b>	<b>62</b>
<b>§4.7 Operation Notices .....</b>	<b>62</b>
<b><i>§5 Diagram for Guns .....</i></b>	<b><i>63</i></b>
§5.1 MIG Torch .....	63
§5.2 TIG Torch.....	65
§5.3 Spool Gun .....	67
<b><i>§6 Welding Trouble Shooting .....</i></b>	<b><i>68</i></b>
§6.1 Troubleshooting.....	68
§6.2 MIG Welding - Trouble Shooting .....	70
§6.3 MIG Wire Feed - Trouble Shooting.....	72
§6.4 DC TIG Welding - Trouble Shooting.....	73
§6.5 MMA Welding - Trouble Shooting .....	75
<b><i>§7 Maintenance &amp; Troubleshooting.....</i></b>	<b><i>77</i></b>
§7.1 Maintenance .....	77
§7.2 List of Error Codes .....	79
§7.3 Electrical Schematic Drawing .....	80

# §1 Safety

**Notice: The instructions are for reference only. The manufacturer reserves the right to explain the differences between the description and the product due to product changes and upgrades!**

Welding and cutting equipment can be dangerous to both the operator and people in or near the surrounding working area, if the equipment is not correctly operated. Equipment must only be used under the strict and comprehensive observance of all relevant safety regulations. Read and understand this instruction manual carefully before the installation and operation of this equipment.

## §1.1 Symbols Explanation



- The above symbols mean warning!

**Notice!** Running parts, getting an electric shock or making contacts with thermal parts will cause damage to your body and others. The underline message is as follows:

**Welding is quite a safe operation after taking several necessary protection measures!**

## §1.2 Machine Operating warnings!

- The following symbols and words explanations are for some damages to your body or others, which could happen during the welding operation. While seeing these symbols, please remind yourself and others to be careful.
- Only people who are trained professionally can install, debug, operate, maintain and repair the welding equipment covered with this Operator's Manual!
- During the welding operation, non-concerned people should NOT be around, especially children!

- After shutting off the machine power, please maintain and examine the equipment according to §7 because of the DC voltage existing in the electrolytic capacitors at the output of the power supply!

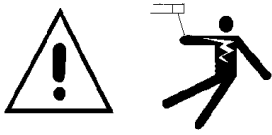

## **ELECTRIC SHOCK CAN KILL**

Touching live electrical parts can cause fatal shocks or severe burns. The electrode and work circuit is electrically live whenever the output is on. The input power circuit and internal machine circuits are also live when power is on. In MIG/MAG welding, the wire, drive rollers, wire feed housing, and all metal parts touching the welding wire are electrically live. Incorrectly installed or improperly grounded equipment is dangerous.

- Never touch live electrical parts.
- Wear dry, hole-free gloves and clothes to insulate your body.
- Be sure to install the equipment correctly and ground the work or metal to be welded to a good electrical (earth) ground according to the operation manual.
- The electrode and work (or ground) circuits are electrically “hot” when the machine is ON. Do not touch these “hot” parts with your bare skin or wet clothing. Wear dry, hole-free gloves to insulate hands.
- In semiautomatic or automatic wire welding, the electrode, electrode reel, welding head, nozzle or semiautomatic welding gun are also electrically “hot”.
- Insulate yourself from work and ground using dry insulation. Make certain the insulation is large enough to cover your full area of physical contact with work and ground.
- Be Careful when using the equipment in small places, falling-off and wet circumstance.
- Always be sure the work cable makes a good electrical connection with the metal being welded. The connection should be as close as possible to the area being welded.
- Maintain the electrode holder, work clamp, welding cable and welding machine in good, safe operating condition. Replace damaged insulation.
- Never dip the electrode in water for cooling.
- Never simultaneously touch electrically “hot” parts of electrode holders connected to two welders because voltage between the two can be the total of the open circuit

voltage of both welders.

- When working above the floor level, use a safety belt to protect yourself from a fall should you get an electric shock!



### **FUMES AND GASES CAN BE DANGEROUS**

Smoke and gas generated whilst welding or cutting can be harmful to people's health. Welding produces fumes and gases. Breathing these fumes and gases can be hazardous to your health.

- Do not breathe the smoke and gas generated whilst welding or cutting, keep your head out of the fumes. Use enough ventilation and/or exhaust at the arc to keep fumes and gases away from the breathing zone. When welding with electrodes which require special ventilation such as stainless or hard facing or on lead or cadmium plated steel and other metals or coatings which produce highly toxic fumes, keep exposure as low as possible and below the Threshold Limit Values using local exhaust or mechanical ventilation. In confined spaces or in some circumstances, outdoors, a respirator may be required. Additional precautions are also required when welding on galvanized steel.
- Do not weld in locations near chlorinated hydrocarbon vapors coming from degreasing, cleaning or spraying operations. The heat and rays of the arc can react with solvent vapors to form phosgene, a highly toxic gas, and other irritating products.
- Shielded gases used for arc welding can displace air and cause injury or death. Always use enough ventilation, especially in confined areas, to insure breathing air is safe.
- Read and understand the manufacturer's instructions for this equipment and the consumables to be used, including the material safety data sheet and follow your employer's safety practices.



### **ARC RAYS: Harmful to people's eyes and skin**

Arc rays from the welding process produce intense visible and invisible ultraviolet and infrared rays that can burn eyes and skin.

- Use a shield with the proper filter and cover plates to protect your eyes from sparks and the rays of the arc when welding or observing open arc welding.
- Use suitable clothing made from durable flame-resistant material to protect your skin

and that of your coworkers from the arc rays.

- Protect other nearby personnel with suitable, non-flammable screening and /or warn them not to watch the arc nor expose themselves to the arc rays or to hot spatter or metal.



### **SELF-PROTECTION**

- Keep all equipment safety guards, covers and devices in position and in good repair. Keep hands, hair, clothing and tools away from V-belts, gears, fans and all other moving parts when starting, operating or repairing equipment.
- Do not put your hands near the engine fan. Do not attempt to override the governor or idler by pushing on the throttle control rods while the engine is running.



**DO NOT** add any fuel near an open-flame welding arc or when the engine is running. Stop the engine and allow it to cool before refueling to prevent spilled fuel from vaporizing on contact with hot engine parts and igniting. Do not spill fuel when filling tank. If fuel is spilled, wipe it up and do not start engine until fumes have been eliminated.



### **WELDING SPARKS can cause fire or explosion**

Welding on closed containers, such as tanks, drums, or pipes, can cause them to explode. Flying sparks from the welding arc, hot work piece, and hot equipment can cause fires and burns. Accidental contact of electrode to metal objects can cause sparks, explosion, overheating, or fire. Check and be sure the area is safe before doing any welding.

- Remove fire hazards material from the welding area. If this is not possible, cover them to prevent the welding sparks from starting a fire. Remember that welding sparks and hot materials from welding can easily go through small cracks and openings to adjacent areas. Avoid welding near hydraulic lines. Have a fire extinguisher readily available.
- Where compressed gases are to be used at the job site, special precautions should be used to prevent hazardous situation.

- When not welding, make certain no part of the electrode circuit is touching the work or ground. Accidental contact can cause overheating and create a fire hazard.
- Do not heat, cut or weld tanks, drums or containers until the proper steps have been taken to insure that such procedures will not cause flammable or toxic vapors from substances inside. They can cause an explosion even though they have been “cleaned”.
- Vent hollow castings or containers before heating, cutting or welding. They may explode.
- Sparks and spatter are thrown from the welding arc. Wear oil free protective garments such as leather gloves, heavy shirt, cuff less trousers, high shoes and a cap over your hair. Wear earplugs when welding out of position or in confined places. Always wear safety glasses with side shields when in a welding area.
- Connect the work cable to the work as close to the welding area as practical. Work cables connected to the building framework or other locations away from the welding area increase the possibility of the welding current passing through lifting chains, crane cables or other alternate circuits. This can create fire hazards or overheat lifting chains or cables until they fail.



### **Rotating parts may be dangerous**

- Use only compressed gas cylinders containing the correct shielding gas for the process used and properly operating regulators designed for the gas and pressure used. All hoses, fittings, etc. should be suitable for the application and maintained in good condition.
- Always keep cylinders in an upright position securely chained to an undercarriage or fixed support.
- Cylinders should be located:
  - Away from areas where they may be struck or subjected to physical damage.
  - At a safe distance from arc welding or cutting operations and any other source of heat, sparks, or flame.
- Never allow the electrode, electrode holder or any other electrically “hot” parts to touch a gas cylinder.

- Keep your head and face away from the cylinder valve outlet when opening the cylinder valve.
- Valve protection caps should always be in place and hand tight except when the cylinder is in use or connected for use.



### **Gas Cylinders.**

Shielding gas cylinders contain gas under high pressure. If damaged, a cylinder can explode. Because gas cylinders are normally part of the welding process, be sure to treat them carefully. CYLINDERS can explode if damaged.

- Protect gas cylinders from excessive heat, mechanical shocks, physical damage, slag, open flames sparks, and arcs.
- Insure cylinders are held secure and upright to prevent tipping or falling over.
- Never allow the welding electrode or earth clamp to touch the gas cylinder, do not drape welding cables over the cylinder.
- Never weld on a pressurised gas cylinder, it will explode and kill you.
- Open the cylinder valve slowly and turn your face away from the cylinder outlet valve and gas regulator.



### **Gas build up.**

The build up of gas can causes a toxic environment, deplete the oxygen content in the air resulting in death or injury. Many gases use in welding are invisible and odourless.

- Shut off shielding gas supply when not in use.
- Always ventilate confine spaces or use approved air-supplied respirator.



### **Electric and Magnetic Fields.**

Electric current flowing through any conductor causes localized Electric and Magnetic Fields (EMF). The discussion on the effect of EMF is ongoing in the entire world. Up to now, no material evidences show that EMF may have effects on health. However, the research on the effect of EMF is still ongoing. Before any conclusion, we should minimize exposure to EMF as few as possible. In order to minimize EMF, we should use the following procedures:

- Route the electrode and work cables together – Secure them with tape when possible.
- All cables should be put away and far from the operator.
- Never coil the power cable around your body.
- Make sure welding machine and power cable to be far away from the operator as far as possible according to the actual circumstance.
- Connect the work cable to the workpiece as close as possible to the area being welded.
- The people with heart-pacemaker should be away from the welding area.



### **Noise can damage hearing**

Noise from some processes or equipment can damage hearing. You must protect your ears from loud noise to prevent permanent loss of hearing.

- To protect your hearing from loud noise, wear protective ear plugs and/or ear muffs. Protect others in the workplace.
- Noise levels should be measured to be sure the decibels (sound) do not exceed safe levels.



### **Hot parts**

Items being welded generate and hold high heat and can cause severe burns. Do not touch hot parts with bare hands. Allow a cooling period before working on the welding gun. Use insulated welding gloves and clothing to handle hot parts and prevent burns.

## **§1.3 EMC device classification**



### **Radiation Class A Device.**

- Only can be used in the industrial area
- If it is used in other area, it may cause connection and radiation problems of circuit.

### **Radiation Class B device.**

- It can meet the radiation requirements of residential area and industrial area. It also can be used in residential area which power is supplied by public low voltage circuit.
- EMC device can be classified by power nameplate or technical data.

## §1.4 EMC measure



In the special situation, the specified area may be affected, the standard of radiation limit value has been complied with (eg: The device, which is easy effected by electromagnetism, is used at the installation location, or there is radio or TV near the installation location). In this condition, the operator should adopt some appropriate measures to remove interference.

According to the domestic and international standards, the ambient devices' electromagnetism situation and anti-interference ability must be checked:

- Safety device
- Power line, Signal transmission line and Data transmission line
- Data processing equipment and telecommunication equipment
- Inspection and calibration device

The effective measures avoid the problem of EMC:

a) Power source

Even though the power source connection meet rules, we still need to take additional measure to remove the electromagnetic interference. (eg: Use the right power filter.)

b) The welding line

- Try to shorten the length of cable
- Put the cable together
- Be Far away from other cable

c) Equipotential connection

d) Ground connection of work-piece

- When necessary, use appropriate capacitance to connect the ground

e) Shielding, when necessary

- Shield the ambient devices
- Shield the whole welding machine

## §1.5 Warning label

The device with a warning label. **Do not remove, destroy or cover this label.** These warnings are intended to avoid incorrect device operations that could result in serious personal injury or property damage.

## §2 Overview

### §2.1 Features

- New panel design: More trendy and humanized.
- LCD screen for accurate setting & feedback of welding output.
- New PWM technology and IGBT inverter technology.
- Active PFC technology for increased duty cycle and energy efficiency.
- Multi voltage input, can use with long extension lead.
- MIG/MAG with Synergic programs for aluminum, mill steel, stainless steel and CuSi
  - 2T /4T/Spot Weld welding mode
  - function parameter adjustment
- MMA function (Stick electrode)
  - Hot start (improves electrode starting)
  - Adjustable Arc Force
- TIG
  - Lift Arc ignition (prevents tungsten sticking during arc ignition)
  - 2T /4T Trigger Control
  - Adjustable Down slope
  - Spot welding mode for TIG HF
- Internal wire feeder, gear driven for up to 5kg spool.
- Euro style MIG torch connection.
- IP21S rating for environmental/safety protection.
- Spool Gun Connection.

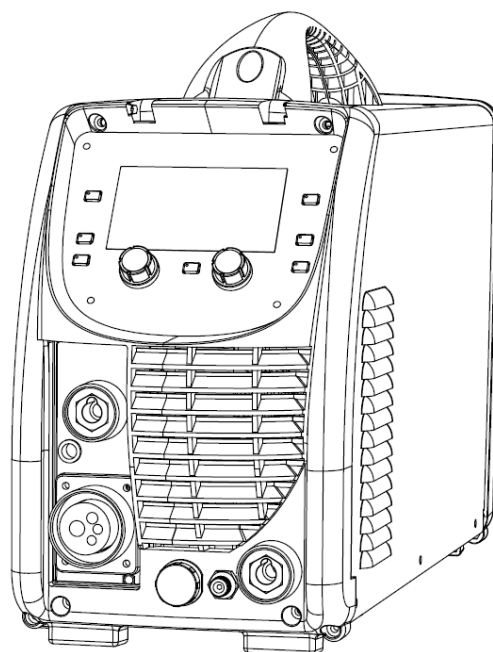

## §2.2 Technical Data

Models	MULTIMIG 200 PRO									
Parameters										
Input Voltage (V)	1-110±10%					1-230±10%				
Frequency (HZ)	50/60									
	MIG		TIG		MMA		MIG		MMA	
	DC	AC	DC	AC	DC	DC	AC	DC	AC	DC
Input Current (A)	37.0	34.9	35.4	38.3	39.9	27.4	21.7	21.9	28.6	31.4
Input Power (KW)	4.1	3.8		4.2	4.4	6.3	5.0		6.6	7.2
Welding Current (A)	30~140		10~160		10~130		30~200		10~200	
No-load Voltage (V)	72									
Duty cycle (40°C)	30%	140A	30%	160A	25%	130A	30% 200A			
	60%	100A	60%	115A	60%	85A	60% 145A			
	100%	80A	100%	90A	100%	65A	100% 110A			
Power Factor (%)	0.99									
Diameter (mm)	Fe: 0.6/0.8/0.9/1.0									
	SS: 0.8/1.0									
	Flux-Cored: 0.6/0.8/0.9/1.0									
	Al: 1.2									
Protection class	IP21S									
Circuit breaker	JD03-A1 30A									
Dimensions (mm)	610*220*405									
Weight (Kg)	20.8									

**Note: The above parameters are subject to change with future machine improvement!**

## §2.3 Brief Introduction

MULTIMIG series of welding machines is a new inverter-based MIG/MMA/TIG Welding machine with Synergic Programs. The MIG function allows you to weld with Gas Shielded wire applications giving excellent, professional welding results. Easy step-less adjustment of voltage and wire feed coupled with the screen allows easy setting of welding parameters. MULTIMIG series of welding machines features MIG welding with Synergic welding programs designed for ease of use with your selected gas mixture. The operator selects the gas mixture and wire diameter they are using then simply start welding. Once this is done the operator can make fine adjustments to the voltage for even greater control of the weld pool. The added Lift-Arc DC TIG capability delivers

perfect arc ignition every time and a remarkably smooth stable arc produces high quality TIG welds. TIG functionality includes adjustable Down Slope & Post Gas as well as being gas solenoid-valve equipped. The stick welding (MMA) capability delivers easy electrode welding with high quality results, including cast Iron, stainless and low hydrogen. An additional feature is the Spool gun ready function that allows the simple connection of Spool Gun for the use of thin or softer wires that don't have the column strength to feed through MIG torches, such as aluminum wire.

MULTIMIG series of arc welding machine is an industrial quality machine that is suitable for all positions welding for various plates made of stainless steel, carbon steel, alloyed steel etc. Applications applied to pipe installment, petrochemical, architecture equipment, car repair, bicycle repair, handicraft and common steel fabrication.

MULTIMIG series of welding machines has built-in automatic protection functions to protect the machines from over-voltage, over-current and over-heat. If any one of the above problems happens, the alarm lamp on the front panel will be lit and output current will be shut off automatically for the machine to protect itself and prolong the equipment using life.

## §2.4 Duty cycle and Over-heat

The letter "X" stands for Duty Cycle, which is defined as the portion of the time a welding machine can weld continuously with its rated output current within a certain time cycle (10 minutes).

The relation between the duty cycle "X" and the output welding current "I" is shown as the right figure.

If the welding machine is overheating, the IGBT over-heat protection sensing will send a signal to the welding machine control unit to cut the output welding current OFF and light the over-heat pilot lamp on the front

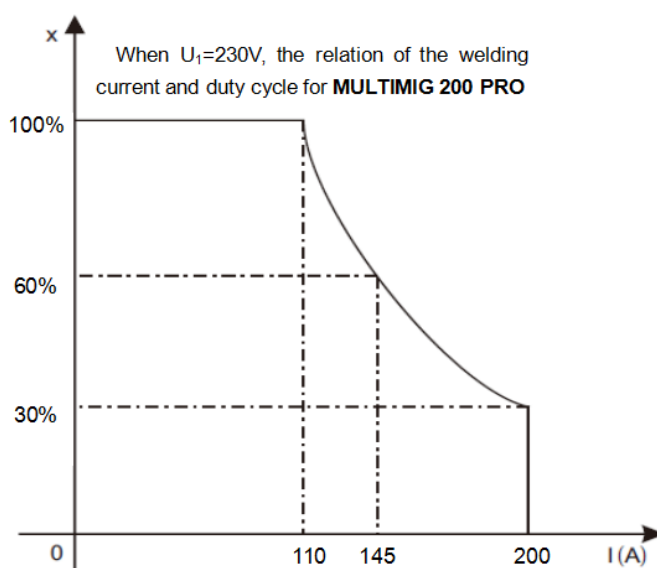

panel. In that case, the machine should not be welding for 10~15 minutes to cool down with the fanrunning. When operating the machine again, the welding output current or the duty cycle should be reduced.

## §2.5 Working Principle

The working principle of BT MIG series welding machine is shown as the following figure. Single-phase 110V/230V work frequency AC is rectified into DC (320V), then is converted to medium frequency AC (about 20KHz) by 1st inverter device (IGBT), after reducing voltage by medium transformer (the main transformer) and rectifying by medium frequency rectifier (fast recovery diodes), and is outputted by two ways. One is DC output, the other is AC output after 2nd inverter device (IGBT).

The circuit uses Hall sensor to realize current feedback control technology to insure current output stably when MMA or TIG. And adopts voltage feedback control technology to insure voltage output stably when MIG. Meanwhile, the welding current parameter can be adjusted continuously and infinitely to meet with the requirements of welding craft.

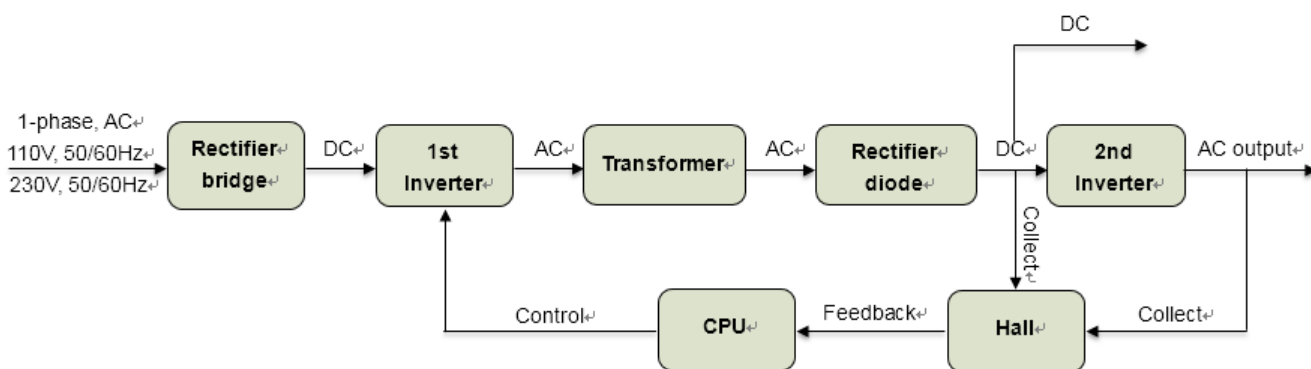

## §2.6 Volt-Ampere Characteristic

MULTIMIG series of welding machines has an excellent volt-ampere characteristic, whose graph is shown as the following figure. The relation between the rated loading voltage  $U_2$  and welding current  $I_2$  is as follows:  $U_2=14+0.05I_2$  (V).

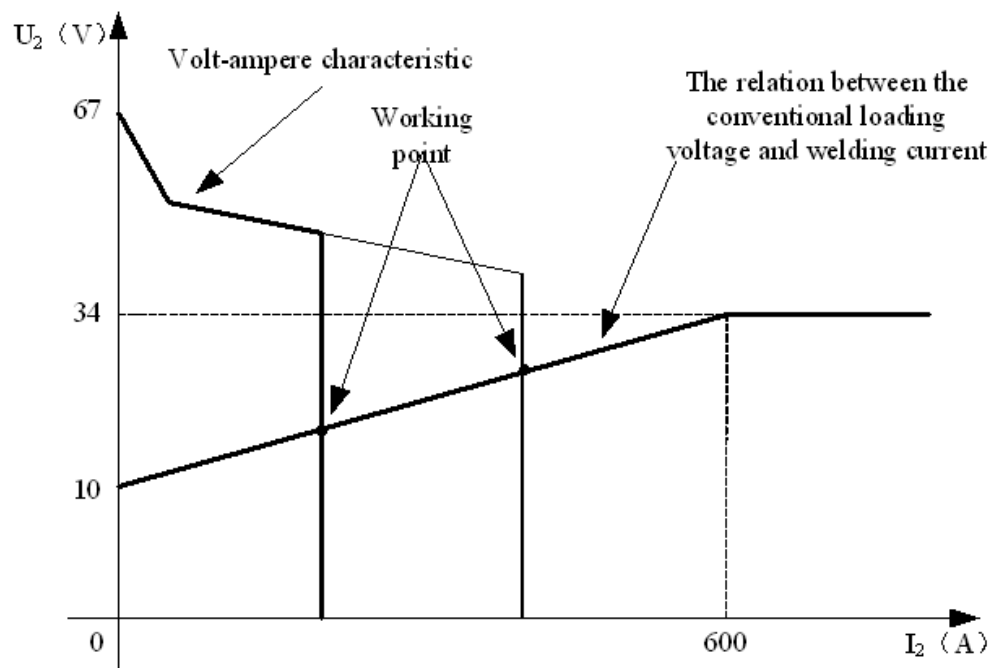

## §3 Panel Functions & Descriptions

### §3.1 Machine Layout Description

#### Front and rear panel layout of welding machine

1. Positive (+) welding power output connection socket.
2. Polarity change power connection.
3. MIG torch euro connector.
4. 9 core air socket
5. TIG torch gas connector.
6. Negative (-) welding power output connection socket.
7. Power switch.
8. Gas inlet connector.
9. Input power cable.

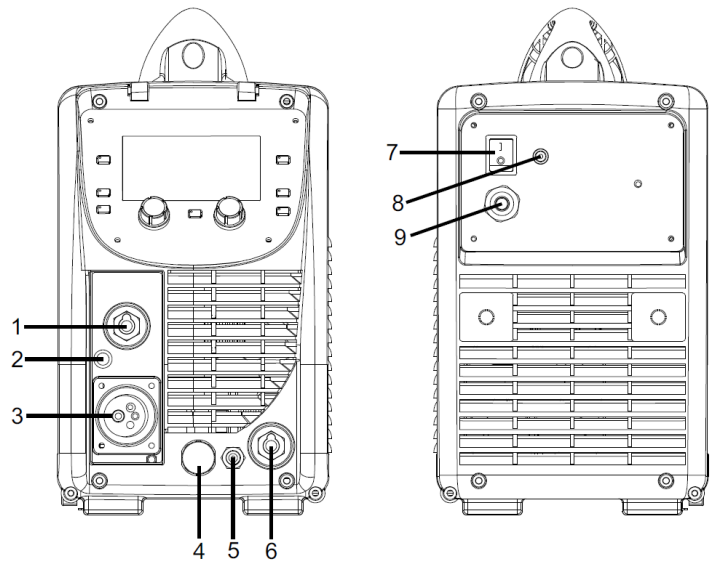

#### Wire Feeder of welding machine

10. Spool holder.
11. Wire feed tension adjustment.
12. Wire feed tension arm.
13. Wire feeder inlet guide.
14. Wire drive roller.

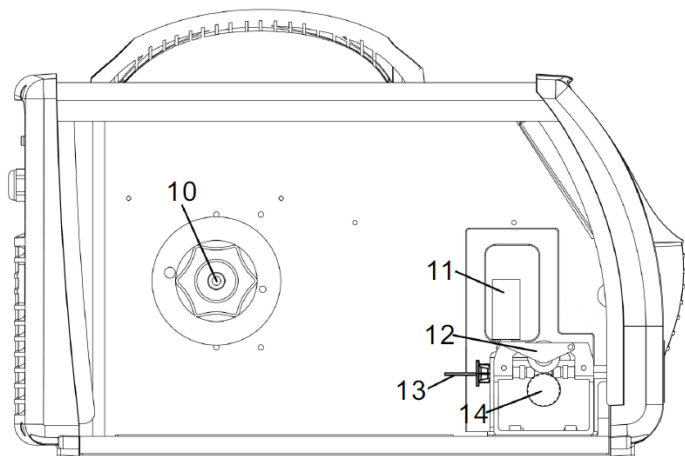

## §3.2 Layout for Control panel

### §3.2.1 Control panel

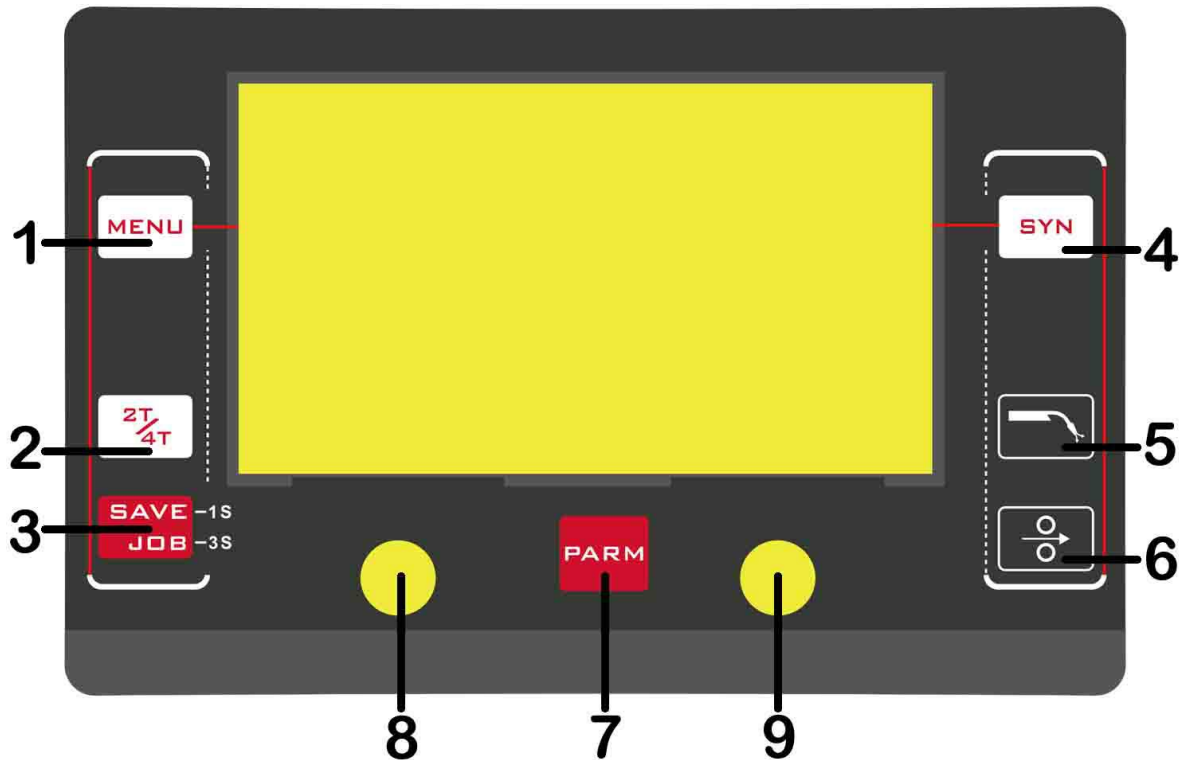

1. **Welding mode button:** Press it to select Stick DC/ Stick AC/ TIG HF/ TIG Lift/ MIG Manual/ MIG Synergic welding mode.
2. **Trigger mode button:** Press it to select 2T or 4T trigger mode.
3. **JOB button:** Press it for 3s to open JOB program and press it for 1s to save parameters into JOB number.
4. **SYN system button:** Press it to select wire material, wire diameter and type of gas.
5. **Air check button:** Press it to check whether the machine isn't air-connected or the gas passage isn't smooth.
6. **Manual wire feed button.**
7. **Function button:** Press it to select parameters or enter the function interface.
8. **L parameter knob:** Press it to select parameters and turn it to adjust values, such as welding current. In function interface, turn it to select parameters.
9. **R parameter knob:** Press it to select parameters and turn it to adjust values.

### §3.2.2 MMA AC/DC display introduction

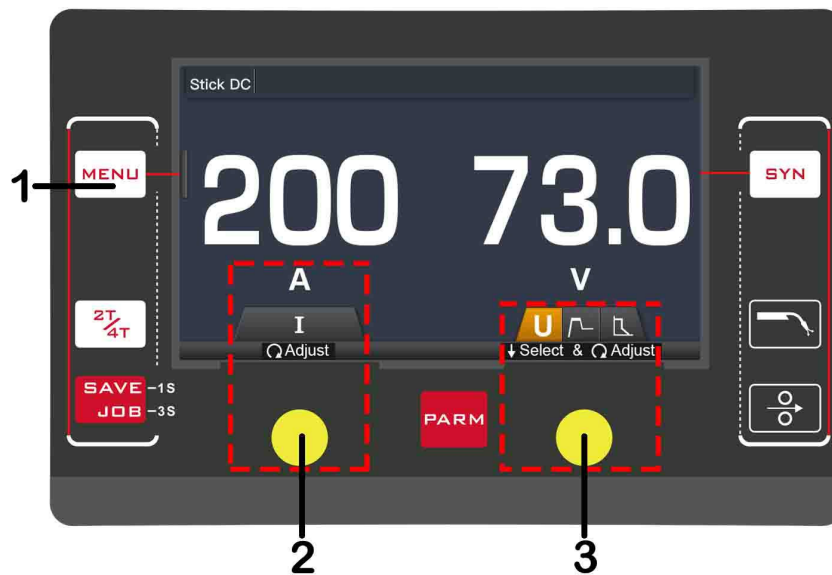

1. **Welding mode button:** Press it to select Stick DC or Stick AC welding mode.
2. **L parameter knob:** Turn it to welding current.
3. **R parameter knob:** Press it to select Hot Start or Arc Force and turn it to adjust values.

#### Hot start

Hot start provides extra power when the weld starts to counteract the high resistance of the electrode and workpiece as the arc is started. Setting range: 0~10.

#### Arc force

An MMA welding power source is designed to produce constant output current. This means with different types of electrode and arc length; the welding voltage varies to keep the current constant. This can cause instability in some welding conditions as MMA welding electrodes will have a minimum voltage they can operate with and still have a stable arc.

Arc Force control boosts the welding power if it senses the welding voltage is getting too low. The higher the arc force adjustment, the higher the minimum voltage that the power source will allow. This effect will also cause the welding current to increase. 0 is Arc Force off, 10 is maximum Arc Force. This is practically useful for electrode types that have a higher operating voltage requirement or joint types that require a short arc length such as out of position welds.

### §3.2.3 TIG HF/Lift display introduction

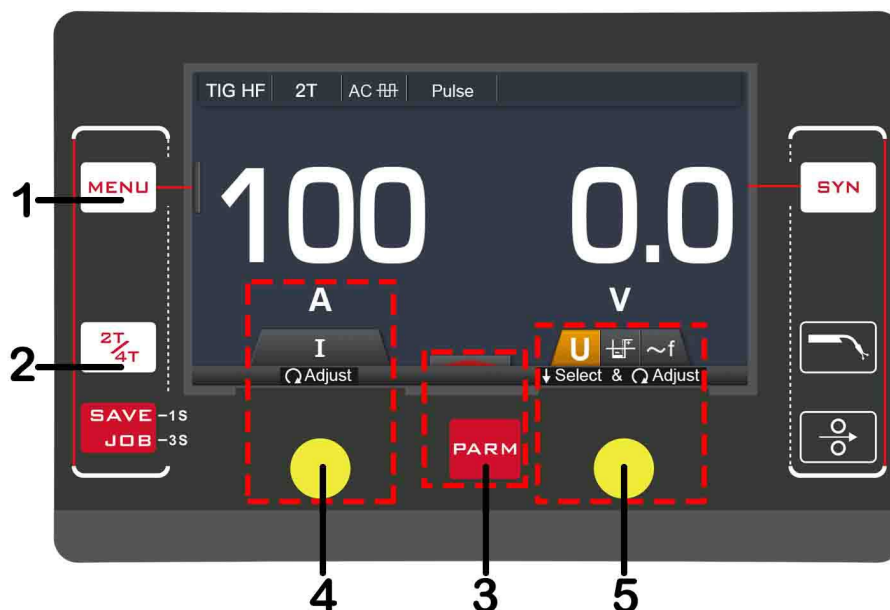

1. **Welding mode button:** Press it to enter TIG HF or TIG Lift welding mode.
2. **Trigger mode button:** Press it to select 2T or 4T trigger mode.
3. **Function button:** Press it to enter the function interface.
4. **L parameter knob:** Turn it to adjust welding current. In function interface, turn it to select parameters, such as trigger mode and Post Flow time.
5. **R parameter knob:** Turn it to select AC Balance (-5~5) or AC Frequency (50~250Hz) and turn it to adjust values. (Available only in AC mode.) In function interface, turn it to select parameters, such as trigger mode and Post Flow time. \*

\*Denotes more detailed explanation of function to follow.

## Further Controls Explained

### AC Balance

Only be available in AC welding mode. Adjust the balance as a percentage between the forward and reverse current cycles when welding in AC output mode. The reverse part of the AC cycle gives the 'cleaning' effect on the weld material, while the forward cycle melts the weld material. Neutral setting is 0. Increased reverse cycle bias will give greater cleaning effect, less weld penetration and more heat in the torch tungsten, which gives the disadvantage of reducing the output current that can be used for a given

tungsten size, to prevent the tungsten overheating. Increased forward cycle bias will give the opposite effect, less cleaning effect, greater weld penetration and less heat in the tungsten.

## AC Frequency

Only be available in AC welding mode. Increasing AC frequency will focus the shape of the arc, resulting in a tighter, more controlled arc causing increased penetration and less heated affected area for the same current setting. Slower frequency will result in a wider, softer arc shape.

## Function interface:

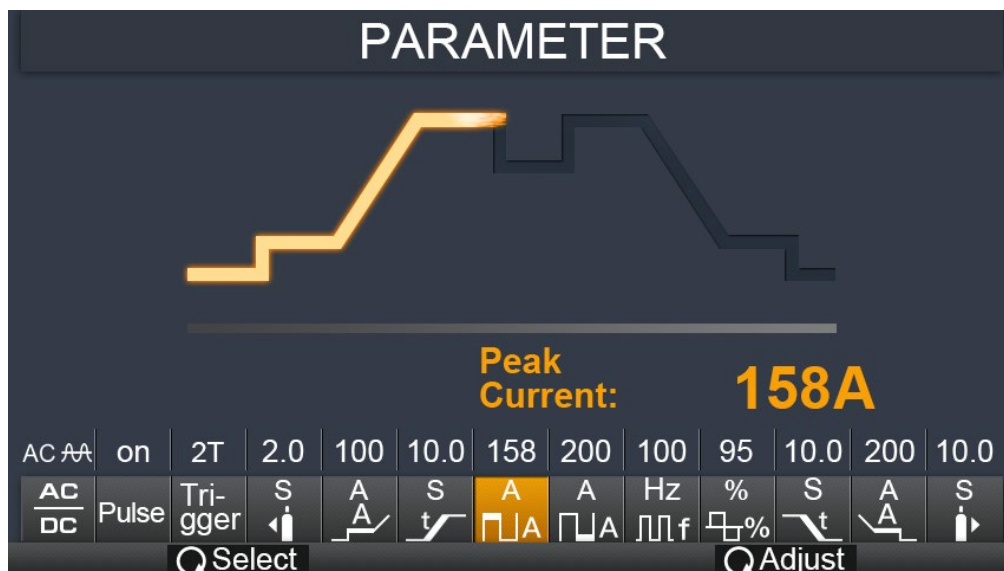

1. **Output waveform:** Press it to select DC output or AC wave output.



2. **Pulse mode:** ON or OFF.
3. **Trigger mode:** 2T/ 4T/ Spot weld. (Spot is only available in TIG HF welding mode.) \*
4. **Pre Flow:** 0~2s.
5. **Pre Current:** 10~200A.
6. **Up Slope:** 0~10s.
7. **Peak Current:** 10~200A.
8. **Base Current:** 10~200A. (Only available in Pulse mode.)

9. **Pulse Frequency:** 0.5~999Hz. (Only available in Pulse mode.) \*

10. **Duty Cycle:** 5~95%. (Only available in Pulse mode.) \*

11. **Down Slope:** 0~10s.

12. **Post Current:** 10~200A.

13. **Post Flow:** 0~10s.

\*Denotes more detailed explanation of function to follow.

## Further Controls Explained

### 2T Mode (3)

The trigger is pulled and held on to activate the welding circuit, when the trigger is released, the welding circuit stops.

This function without the adjustment of start current and crater current is suitable for the Re-tack welding、transient welding、thin plate welding and so on.

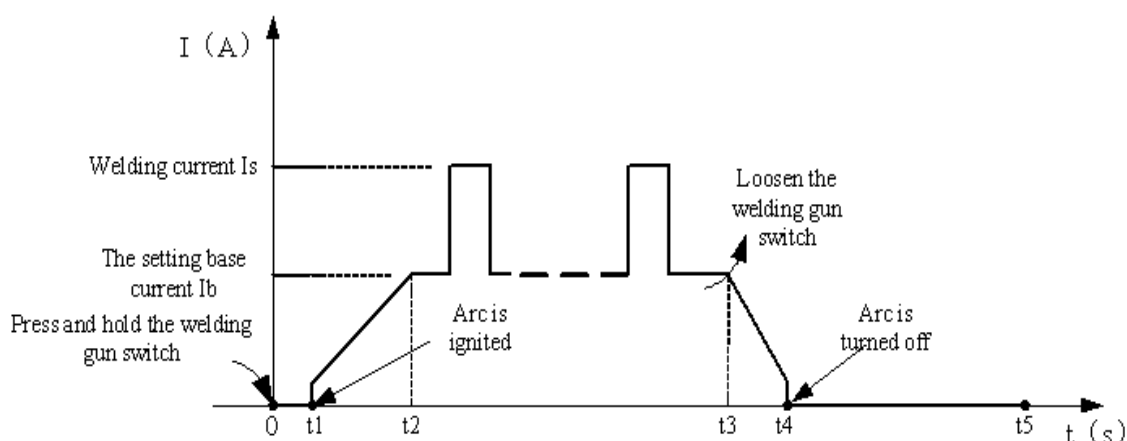

#### Introduction:

- (1) 0: Press the gun switch and hold it. Electromagnetic gas valve is turned on. The shielding gas starts to flow.
- (2) 0~t<sub>1</sub>: Pre-gas time (0.1~2.0s)
- (3) t<sub>1</sub>~t<sub>2</sub>: Arc is ignited and the output current rises to the setting welding current ( $I_w$  or  $I_b$ ) from the min welding current.
- (4) t<sub>2</sub>~t<sub>3</sub>: During the whole welding process, the gun switch is pressed and held without releasing.

**Note:** Select the pulsed output, the base current and welding current will be outputted

alternately; otherwise, output the setting value of welding current;

- (5)  $t_3$ : Release the gun switch, the welding current will drop in accordance with the selected down-slope time.
- (6)  $t_3 \sim t_4$ : The current drops to the minimum welding current from the setting current ( $I_w$  or  $I_b$ ), and then arc is turned off.
- (7)  $t_4 \sim t_5$ : Post-gas time, after the arc is turned off. You can adjust it (0.0~10s) through turning the knob on the front panel.
- (8)  $t_5$ : Electromagnetic gas valve turned off, the shield gas stops to flow, and welding is finished.

### 4T Mode (3)

This is known as 'latching' mode. The trigger is pulled once and released to activate the welding circuit, pulled and released again to stop the welding circuit. This function is useful to longer welds as the trigger is not required to be held on continuously. TIG series of welding machines also has more current control options that can be used in 4T mode.

The start current and crater current can be pre-set. This function can compensate the possible crater that appears at the beginning and end of the welding. Thus, 4T is suitable for the welding of medium thickness plates.

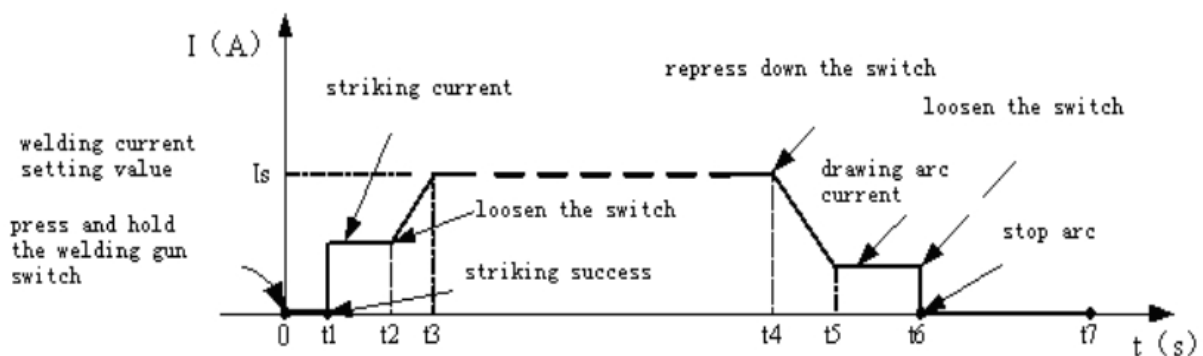

### Introduction:

- (1) 0: Press and hold the gun switch, Electromagnetic gas valve is turned on. The shielding gas starts to flow;
- (2)  $0 \sim t_1$ : Pre-gas time (0.1~2.0S);
- (3)  $t_1 \sim t_2$ : Arc is ignited at  $t_1$  and then output the setting value of start current;
- (4)  $t_2$ : Loosen the gun switch, the output current slopes up from the start current;

- (5)  $t_2 \sim t_3$ : The output current rises to the setting value ( $I_w$  or  $I_b$ ), the upslope time can be adjusted;
- (6)  $t_3 \sim t_4$ : Welding process. During this period, the gun switch is loosen;
 

**Note:** Select the pulsed output, the base current and welding current will be outputted alternately; otherwise, output the setting value of welding current;
- (7)  $t_4$ : Press the torch switch again, the welding current will drop in accordance with the selected down-slope time.
- (8)  $t_4 \sim t_5$ : The output current slopes down to the crater current. The downslope time can be adjusted;
- (9)  $t_5 \sim t_6$ : The crater current time;
- (10)  $t_6$ : Loosen the gun switch, stop arc and keep on argon flowing;
- (11)  $t_6 \sim t_7$ : Post-gas time can be set by the post-gas time adjustment knob on the front panel (0.0~10S);
- (12)  $t_7$ : Electromagnetic valve is closed and stop argon flowing. Welding is finished.

### **Pulse frequency (9)**

Only be available when pulse mode is selected. Set the rate that the welding output alternates between the peak and base current settings.

### **Duty Cycle (10)**

Only be available when pulse mode is selected. Set the time proportion as a percentage between the peak current and base current when using pulse mode. Neutral setting is 50%, the time period of the peak current and base current pulse is equal. Higher pulse duty setting will give greater heat input, while lower pulse duty will have the opposite effect.

### Function interface of Spot weld:

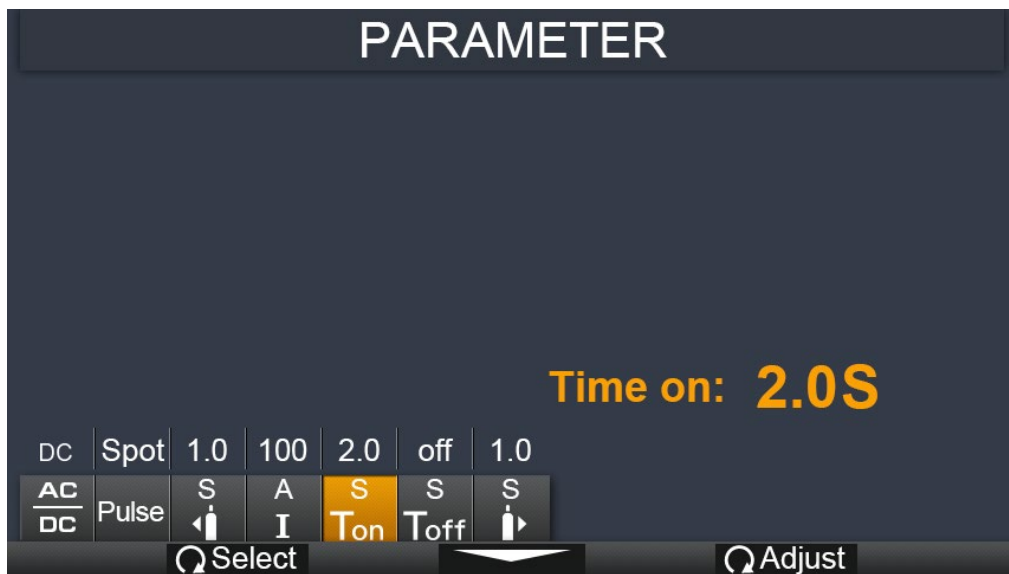

1. **Post Flow:** 0.1~2s.
2. **Welding current:** 10~200A.
3. **T<sub>on</sub> time:** 0.2~1s.
4. **T<sub>off</sub> time:** 0~10s.
5. **Post Flow:** 0.1~10s.

### Spot Weld trigger mode:

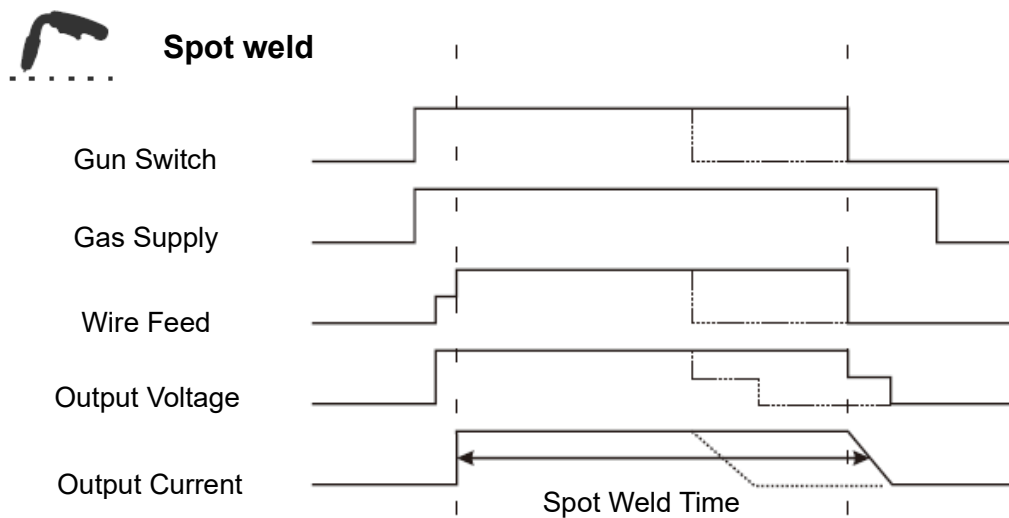

### §3.2.4 MIG Manual display introduction

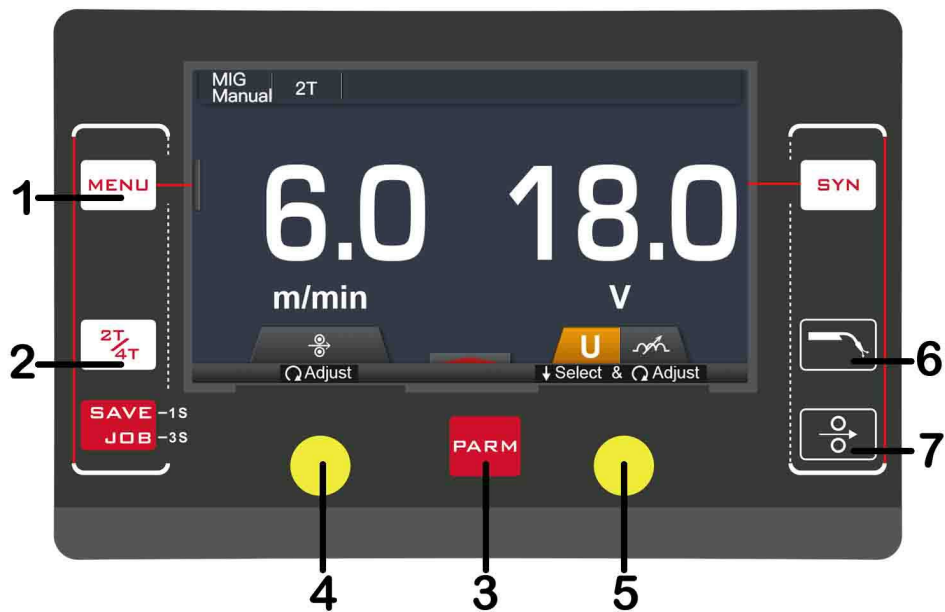

1. **Welding mode button:** Press it to select MIG Manual welding mode.
2. **Trigger mode button:** Press it to select 2T or 4T trigger mode.
3. **Function button:** Press it to enter the function interface.
4. **L parameter knob:** Turn it to adjust wire feeding speed. In function interface, turn it to select parameters, such as Pre Flow, Post Flow.
5. **R parameter knob:** Press it to select welding voltage or inductance. Turn it to adjust value.
6. **Air check button.**
7. **Manual wire button.**

#### Function interface:

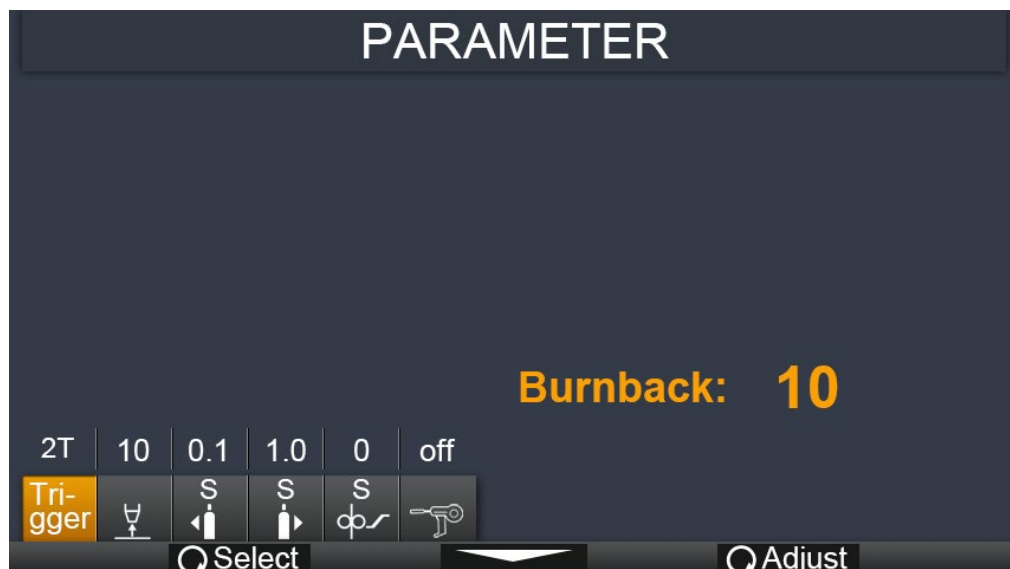

1. **Trigger mode:** 2T or 4T.
2. **Burnback:** 0~10.
3. **Pre Flow:** 0.1~10s.
4. **Post Flow:** 0.1~10s.
5. **Slow Feed:** 0~10.
6. **Spool Gun:** off/ on.

## **Burnback**

Short-circuit between welding wire and molten pool leads to the increase of current, which leads to the melting speed of welding wire too fast, and the wire feeding speed cannot keep up with, which makes the welding wire and workpiece disconnected. This phenomenon is called “burn back”. This function is to ensure the welding seam is not beautiful after welding. Range: 0-10.

## **Slow feed**

This function is used to regulate the speed of wire feeding increasing. Range: 0-10s.

### **§3.2.5 MIG SYN display introduction**

The operator simply sets the welding current like MIG welding and the machine calculates the optimal voltage and wire speed for the material type, wire type and size and shielding gas being used. Obviously other variables such as welding joint type and thickness, air temperature affect the optimal voltage and wire feed setting, so the program provides a voltage fine tuning function for the synergic program selected. Once the voltage is adjusted in a synergic program, it will stay fixed at this variation when the current setting is changed. To reset the voltage for a synergic program back to factory default, change to another program and back again.

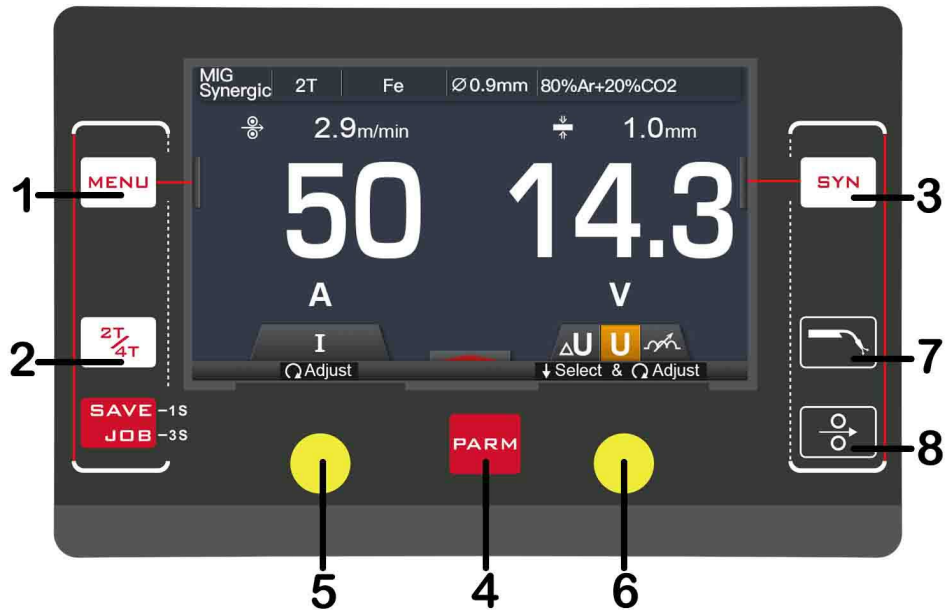

1. **Welding mode button:** Press it to select MIG Manual welding mode.
2. **Trigger mode button:** Press it to select 2T or 4T trigger mode.
3. **SYN system button:** Press it to enter SYN item. Select wire material/ wire diameter and shield gas by using R parameter knob.
4. **Function button:** Press it to enter the function interface.
5. **L parameter knob:** Turn it to adjust wire feeding speed. In function interface, rotate it to select parameters, such as Pre Flow, Post Flow.
6. **R parameter knob:** Press it to select welding voltage or inductance. Turn it to adjust value. In SYN item, turn to select and press to confirm.
7. **Air check button.**
8. **Manual wire button.**

**Function interface:**

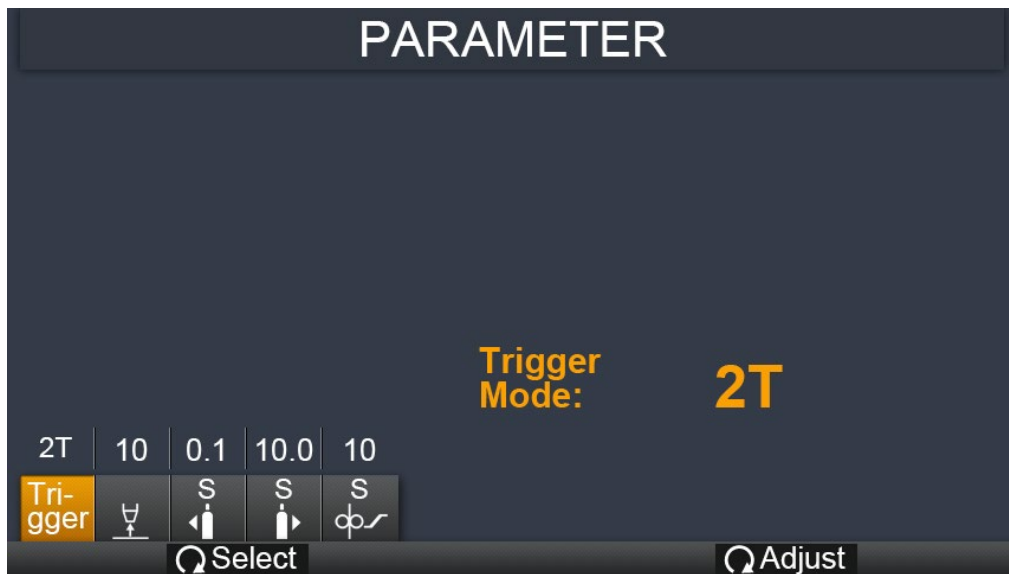

1. **Trigger mode:** 2T or 4T.
2. **Burnback:** 0~10.
3. **Pre Flow:** 0.1~10s.
4. **Post Flow:** 0.1~10s.
5. **Slow Feed:** 0~10.

### §3.2.6 JOB display introduction

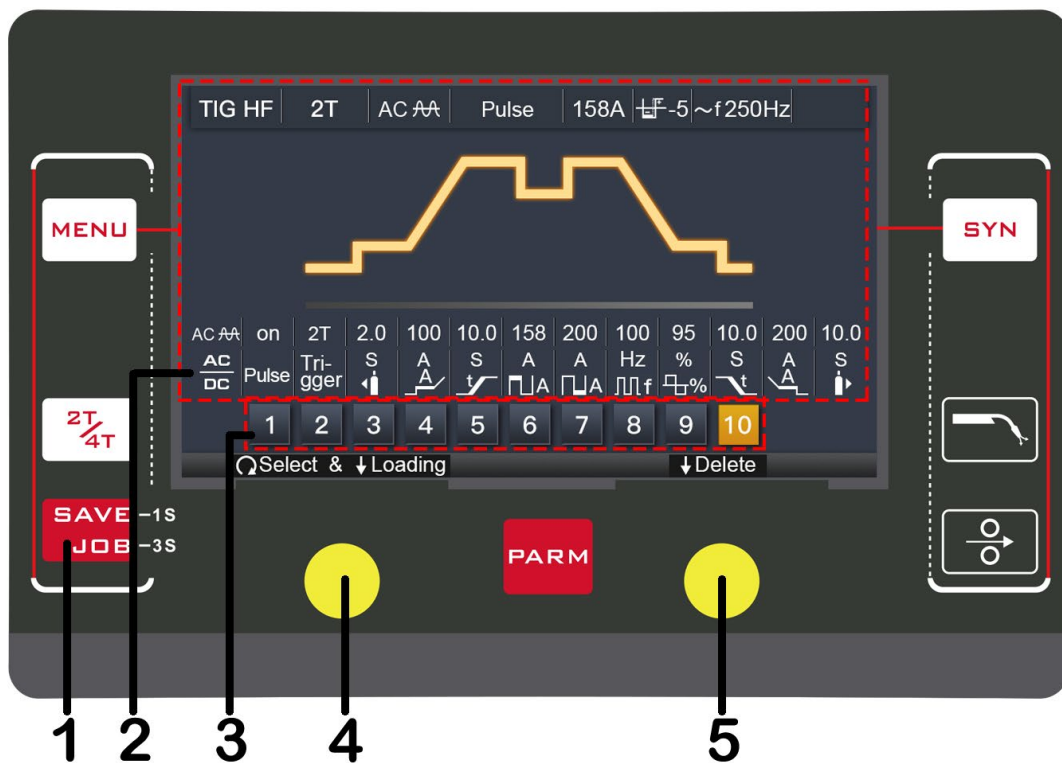

1. **JOB button:** Press it for 3s to enter JOB programs and press it for 1s to save parameters.
2. **Parameters display:** Here are all the selected parameter that you settings.
3. **JOB number display.**
4. **L parameter knob:** Turn it to turn the page and press it to delete the parameters.
5. **R parameter knob:** Turn it to select JOB program number and press it to load the selected JOB program number.

## §4 Installation & Operation

### §4.1 Installation & Operation for MMA Electrode Welding

#### §4.1.1 Set-Up Installation

Two sockets are available on this welding machine, One Positive (+) and one Negative (-) polarity, to connect MMA/Electrode holder cable and earth clamp cable. Various electrodes require different polarity for optimum results and careful attention should be paid to the polarity, refer to the electrode manufacturers information for the correct polarity.

**DCEP:** Electrode connected to Positive (+) output socket.

**DCEN:** Electrode connected to Negative (-) output socket.

**MMA (DC):** Choosing the connection of DCEN or DCEP according to the different electrodes. Please refer to the electrode manual.

**MMA (AC):** No requirements for polarity connection.

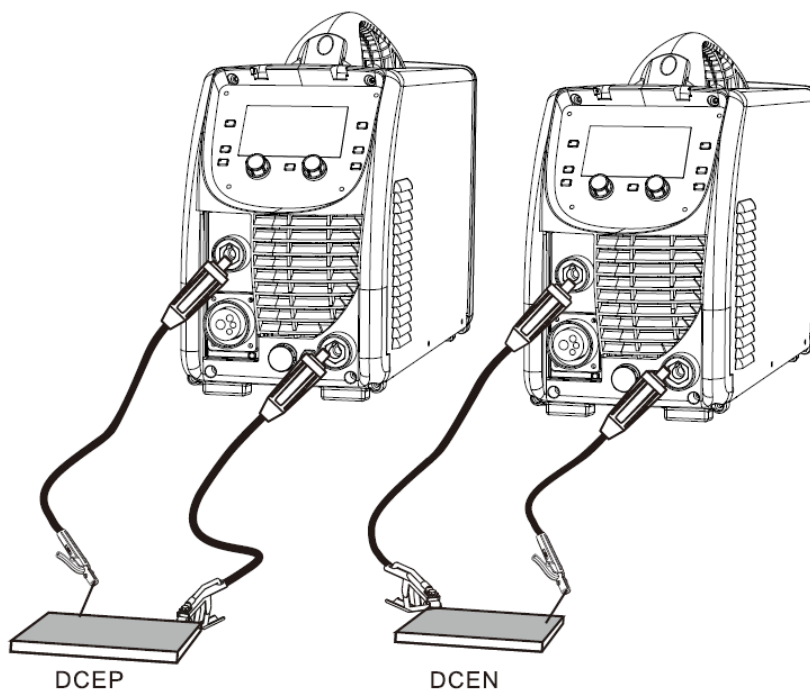

- (1) Turn the power source on and press the welding mode key to MMA welding mode.
- (2) Set the welding current relevant to the electrode type and size being used as recommended by the electrode manufacturer.
- (3) Set the Hot Start and Arc Force as required using knobs and buttons.

- (4) Place the electrode into the electrode holder and clamp tight.
- (5) Strike the electrode against the work piece to create and arc and hold the electrode steady to maintain the arc.

### §4.1.2 MMA/Stick Electrode Welding

One of the most common types of arc welding is manual metal arc welding (MMA) or stick welding. An electric current is used to strike an arc between the base material and a consumable electrode rod or 'stick'. The electrode rod is made of a material that is compatible with the base material being welded and is covered with a flux that releases a gaseous vapor that serve as a shielding gas and providing a layer of slag, both of which protect the weld area from atmospheric contamination. The electrode core itself acts as filler material the residue from the flux that forms slag covering over the weld metal must be chipped away after welding.

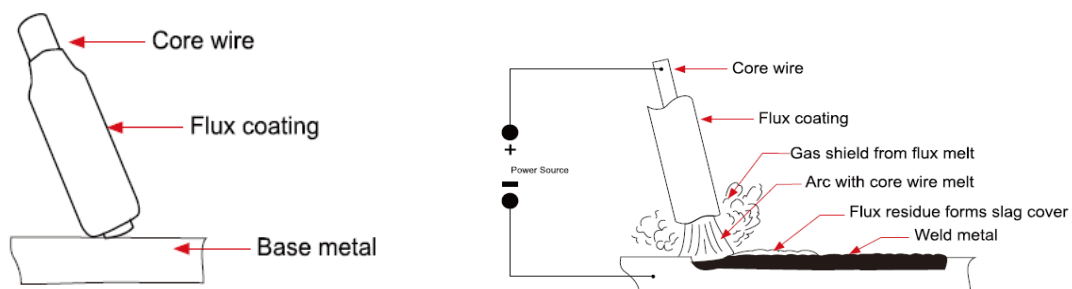

### MMA / Stick Electrode

- The arc is initiated by momentarily touching the electrode to the base metal.
- The melted electrode metal is transferred across the arc into the molten pool and becomes weld metal.
- The deposit is covered and protected by slag from the electrode flux coating.

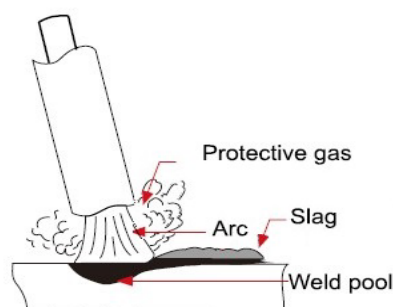

### Flux Properties

- producing a protective gas around the weld area

- providing fluxing elements and deoxidizer
- creating a protective slag coating over the weld
- establishing arc characteristics
- adding alloying elements

Stick electrodes serve many purposes in addition to filler metal to the molten pool. These additional functions are provided mainly by the various coverings on the electrode.

### §4.1.3 MMA Welding Fundamentals

#### Electrode Selection

As a general rule, the selection of an electrode is straight forward, in that it is only a matter of selecting an electrode of similar composition to the parent metal. However, for some metals there is a choice of several electrodes, each of which has particular properties to suit specific classes of work. It is recommend to consult your welding supplier.

Average Thickness of Material	Max Recommended Electrode Diameter
1.0-2.0 mm	2.5 mm
2.0-5.0 mm	3.2 mm
5.0-8.0 mm	4.0 mm
>8.0 mm	5.0 mm

The size of the electrode generally depends on the thickness of the section being welded, and the thicker the section the larger the electrode required. The maximum size of electrodes that may be used for various thicknesses based on a general purpose type 6013 electrode.

#### Welding Current (Amperage)

Electrode Size ø mm	Current Range (Amps)
2.5 mm	60-95
3.2 mm	100-130
4.0 mm	130-165
5.0 mm	165-260

Correct current selection for a particular job is an important factor in arc welding. With the current set too low, difficulty is experienced in striking and maintaining a stable arc. The electrode tends to stick to the work, penetration is poor and beads with a distinct

rounded profile will be deposited. Too high current is accompanied by overheating of the electrode resulting undercut and burning through of the base metal and producing excessive spatter. Normal current for a particular job may be considered as the maximum, which can be used without burning through the work, over-heating the electrode or producing a rough spattered surface. The table shows current ranges generally recommended for a general purpose type 6013 electrode.

### **Arc Length**

To strike the arc, the electrode should be gently scraped on the work until the arc is established. There is a simple rule for the proper arc length; it should be the shortest arc that gives a good surface to the weld. An arc too long reduces penetration, produces spatter and gives a rough surface finish to the weld. An excessively short arc will cause sticking of the electrode and result in poor quality welds. General rule of thumb for down hand welding is to have an arc length no greater than the diameter of the core wire.

### **Electrode Angle**

The angle that the electrode makes with the work is important to ensure a smooth, even transfer of metal. When welding in down hand, fillet, horizontal or overhead the angle of the electrode is generally between 5 and 15 degrees towards the direction of travel. When vertical up welding, the angle of the electrode should be between 80 and 90 degrees to the work piece.

### **Travel Speed**

The electrode should be moved along in the direction of the joint being welded at a speed that will give the size of run required. At the same time, the electrode is fed downwards to keep the correct arc length at all times. Excessive travel speeds lead to poor fusion, lack of penetration etc, while too slow a rate of travel will frequently lead to arc instability, slag inclusions and poor mechanical properties.

### **Material and Joint Preparation**

The material to be welded should be clean and free of any moisture, paint, oil, grease,

mill scale, rust or any other material that will hinder the arc and contaminate the weld material. Joint preparation will depend on the method used include sawing, punching, shearing, machining, flame cutting and others. In all cases edges should be clean and free of any contaminates. The type of joint will be determined by the chosen application.

## §4.2 Installation & Operation for TIG Welding

### §4.2.1 Set-Up for TIG Welding

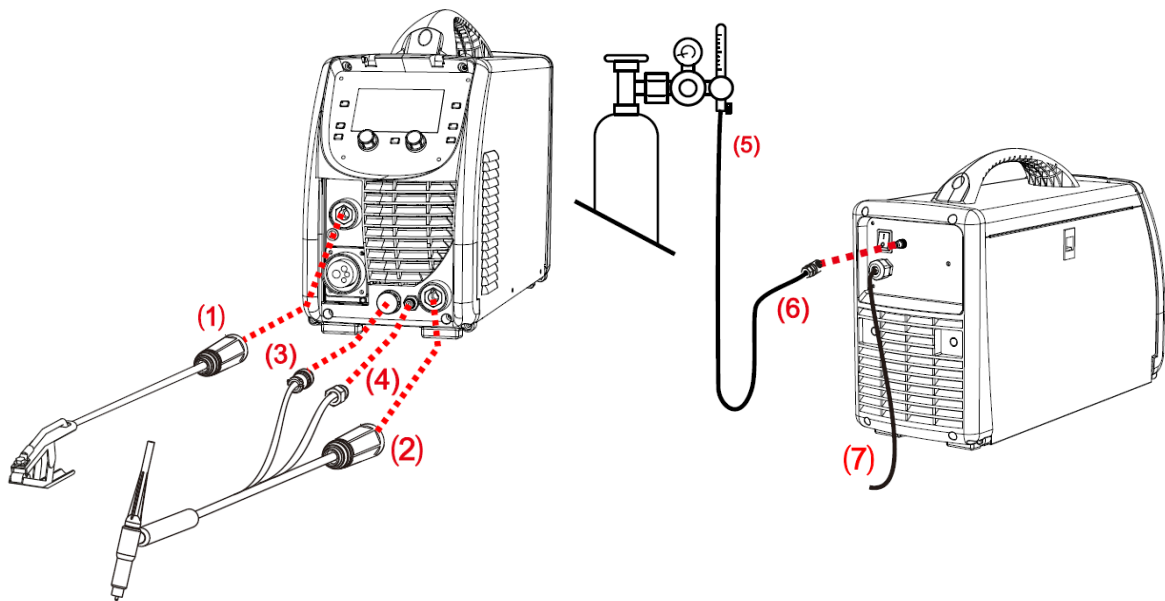

- (1) Insert the earth cable plug into the positive socket on the front of the machine and twist to lock in place.
- (2) Plug the welding torch into the negative socket on the front panel and twist to lock.
- (3) Connect the control cable of torch switch to 9-pin socket on the front of the machine.
- (4) Connect the gas line of TIG torch to outlet gas connector on the front of the machine.
- (5) Connect the gas regulator to the gas cylinder and the gas line to the gas regulator.
- (6) Connect the gas line to the machine inlet gas connector located on the rear panel.
- (7) Connect the power cable of welding machine to the electrical outlet.
- (8) Carefully open the valve of the gas cylinder, set the required gas flow rate.
- (9) Select TIG function on the front panel.
- (10) Set torch operation for 2T, 4T or Spot trigger mode.
- (11) Select welding current as required. The selected welding current will show on

display. Set down slope time as required. The down slope time will show on the digital display.



(12) Assemble front end parts of the TIG torch, fitting a sharpened tungsten suitable for the material to be welded.



(13) Lay the outside edge of the cup on work piece with the tungsten Electrode 1-2mm from the work piece. Press and hold the trigger button on TIG torch to start the gas flow.



(14) With a small movement rotate the gas cup forward so that the tungsten electrode touches the work piece.



(15) Now rotate the Gas Cup in the reverse direction to lift the Tungsten electrode from the work piece to create the arc.



(16) Release the trigger to stop the welding.

**IMPORTANT!** – It is recommended that you check for gas leaks prior to operation and that the operator close the cylinder valve when the machine is not in use.

### §4.2.2 DCTIG Welding

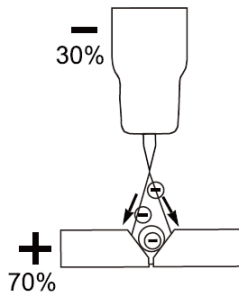

The DC power source uses what is known as DC (direct current) in which the main electrical component, known as electrons, flow in only one direction from the negative terminal (-) to the positive terminal (+). In the DC electrical circuit there is an electrical principle at work which provides that, in a DC circuit, 70% of the energy (heat) is always on the positive side. This is

important because it determines what terminal to connect the TIG torch.

DC TIG welding is a process in which an arc is struck between a tungsten electrode and the metal workpiece. The weld area is shielded by an inert gas flow to prevent contamination of the tungsten, molten pool and weld area. When the TIG arc is struck the inert gas is ionized and superheated changing its' molecular structure which converts it into a plasma stream. This plasma stream that flows between the tungsten and the work piece is the TIG arc and can be as hot as 19,000°C. It is a very pure and concentrated arc which provides the controlled melting of most metals into a weld pool. TIG welding offers the user the greatest amount of flexibility to weld the widest range of materials, thickness and profiles. DC TIG welding is also the cleanest weld with no sparks or spatter.

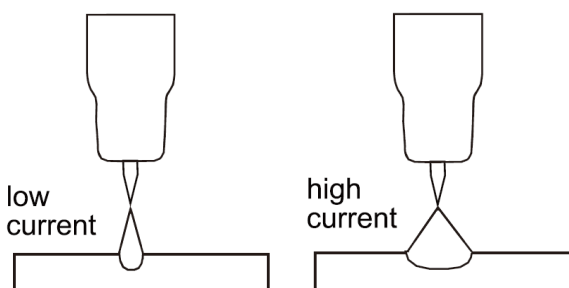
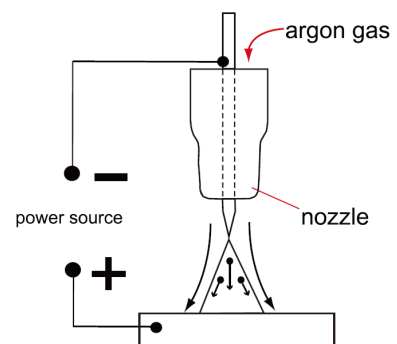

The intensity of the arc is proportional to the current that flows from the tungsten. The welder regulates the welding current to adjust the power of the arc. Typically thin material requires a less powerful arc with less heat to melt the material so less current (amps) is

required, thicker material requires a more powerful arc with more heat so more current (amps) are necessary to melt the material.

### LIFT ARC IGNITION for TIG Welding

Lift Arc is a form of arc ignition where the machine has voltage on the electrode to only a few volts, with a current limit of one or two amps (well below the limit that causes metal to transfer and contamination of the weld or electrode). When the machine detects that the tungsten has left the surface and a spark is present, it immediately (within microseconds) increases power, converting the spark to a full arc. It is a simple, safe lower cost alternative arc ignition process to HF (high frequency) and a superior arc start process to scratch start.



Lay the nozzle on the job without the tungsten touching the work.

Rock the torch sideways so that the tungsten touches the work & hold momentarily.

Rock the torch back in the opposite direction, the arc will ignite as the tungsten lifts off.

Lift the torch to maintain the arc.

### §4.2.3 TIG Welding Fusion Technique

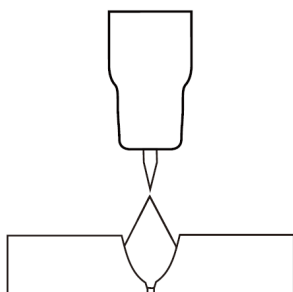

Manual TIG welding is often considered the most difficult of all the welding processes. Because the welder must maintain a short arc length, great care and skill are required to prevent contact between the electrode and the workpiece. Similar to Oxygen/Acetylene torch welding, TIG welding normally requires two hands and in most instances requires the welder to manually feed a filler wire into the weld pool with one hand while manipulating the welding torch in the other. However, some welds combining thin materials can be accomplished without filler metal like edge, corner, and butt joints. This is known as Fusion welding where the edges of the metal pieces are melted together using only the heat and arc force.

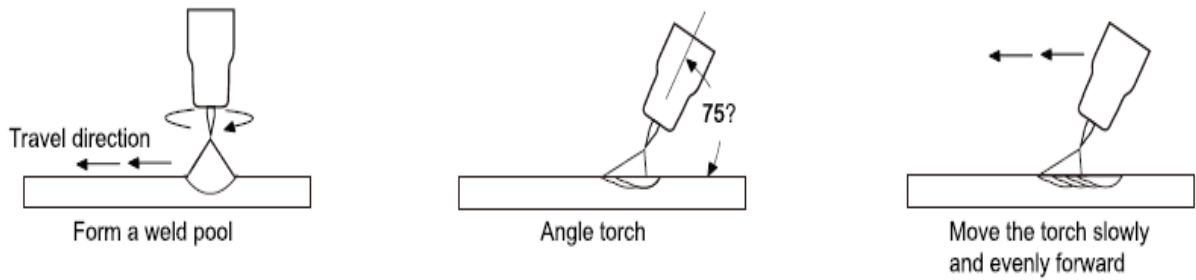

### TIG Welding with Filler Wire Technique

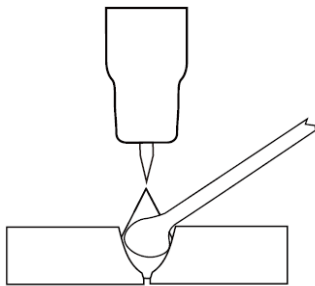

It is necessary in many situations with TIG welding to add a filler wire into the weld pool to build up weld reinforcement and create a strong weld. Once the arc is started the torch tungsten is held in place until a weld pool is created, a circular movement of the tungsten will assist in creating a weld pool of the desired size. Once the weld pool is established tilt the torch at about a 75° angle and move smoothly and evenly along the joint. The filler metal is introduced to the leading edge of the weld pool. The filler wire is usually held at about a 15° angle and fed into the leading edge of the molten pool, the arc will melt the filler wire into the weld pool as the torch is moved forward. A “dabbing” technique can be used to control the amount of filler wire added. The wire is fed into the molten pool and retracted in a repeating sequence as the torch is moved slowly and evenly forward. It is important during the welding to keep the molten end of the filler wire inside the gas shield as this protects the end of the wire from being oxidized and contaminating the weld pool.

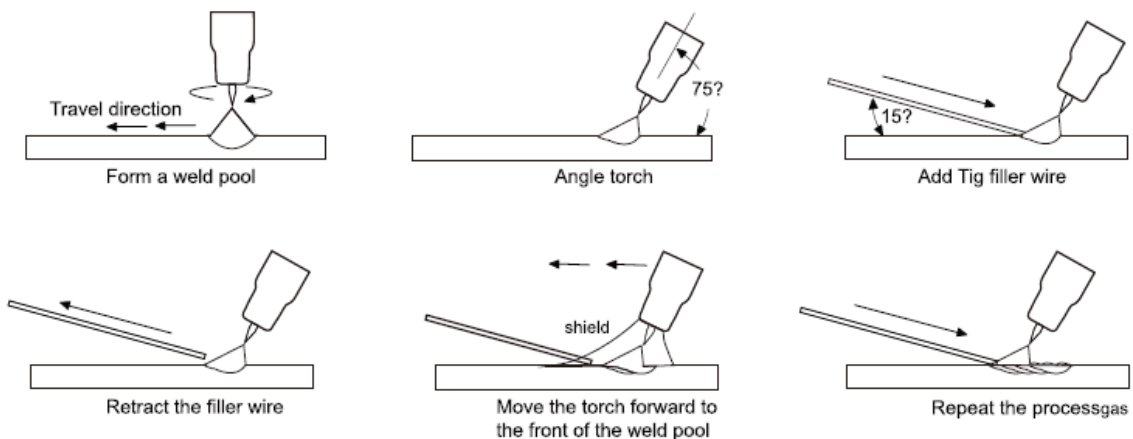

## §4.2.4 Tungsten Electrodes

Tungsten is a rare metallic element used for manufacturing TIG welding electrodes. The TIG process relies on tungsten's hardness and high-temperature resistance to carry the welding current to the arc. Tungsten has the highest melting point of any metal, 3,410 degrees Celsius. Tungsten electrodes are a consumable and come in a variety of sizes, they are made from pure tungsten or an alloy of tungsten and other rare earth elements. Choosing the correct tungsten depends on the material being welded, amps required and whether you are using AC or DC welding current. Tungsten electrodes are color-coded at the end for easy identification.

### **Thoriated (RED)**

Thoriated tungsten electrodes (AWS classification EWTh-2) contain a minimum of 97.30 percent tungsten and 1.70 to 2.20 percent thorium and are called 2% thoriated. They are the most commonly used DC electrodes today and are preferred for their longevity and ease of use. Thorium however is a low-level radioactive hazard and many users have switched to other alternatives. Regarding the radioactivity, thorium is an alpha emitter but when it is enclosed in a tungsten matrix the risks are negligible. Thoriated tungsten should not get in contact with open cuts or wounds. The more significant danger to welder can occur when thorium oxide gets into the lungs. This can happen from the exposure to vapors during welding or from ingestion of material/dust in the grinding of the tungsten. Follow the manufacturer's warnings, instructions, and the Material Safety Data Sheet (MSDS).

### **Pure (Green)**

Pure tungsten electrodes (AWS classification EWP/WP) contain a minimum of 99.5% percent tungsten. Pure Tungsten Electrodes provide conductivity similar to zirconiated electrodes. Pure Tungsten Electrodes work well on AC constant current power sources, such as transformer, for aluminum and magnesium alloys in low to medium temperature applications. They can be used DC electrode negative with a pointed end, or balled for use with AC power sources, they tend to split at higher amperages and should be used for non-critical welds only.

**Ceriated** (Orange) 

Ceriated tungsten electrodes (AWS classification EWCe-2) contain a minimum of 97.30 percent tungsten and 1.80 to 2.20 percent cerium and are referred to as 2% ceriated. Ceriated tungsten performs best in DC welding at low current settings. They have excellent arc starts at low amperages and become popular in such applications as orbital tube welding, thin sheet metal work. They are best used to weld carbon steel, stainless steel, nickel alloys, and titanium, and in some cases it can replace 2% Thoriated electrodes. Ceriated tungsten is best suited for lower amperages it should last longer than Thoriated tungsten higher amperage applications are best left to Thoriated or Lanthanated tungsten.

**Lanthanated** (Gold) 

Lanthanated tungsten electrodes (AWS classification EWLa-1.5) contain a minimum of 97.80 percent tungsten and 1.30 percent to 1.70 percent lanthanum and are known as 1.5% lanthanated. These electrodes have excellent arc starting, a low burn off rate, good arc stability, and excellent re-ignition characteristics. Lanthanated tungsten also share the conductivity characteristics of 2% Thoriated tungsten. Lanthanated tungsten electrodes are ideal if you want to optimize your welding capabilities. They work well on AC or DC electrode negative with a pointed end, or they can be balled for use with AC sine wave power sources. Lanthanated tungsten maintains a sharpened point well, which is an advantage for welding steel and stainless steel on DC or AC from square wave power sources.

**Zirconiated** (White) 

Zirconiated tungsten electrodes (AWS classification EWZr-1) contain a minimum of 99.10 percent tungsten and 0.15 to 0.40 percent zirconium oxide. Most commonly used for AC welding, Zirconiated tungsten produces a very stable arc and is resistant to tungsten spitting. It is ideal for AC welding because it retains a balled tip and has a high resistance to contamination. Its current-carrying capacity is equal to or greater than that of thoriated tungsten. Zirconiated tungsten is not recommended for DC welding.

### Tungsten Electrodes Rating for Welding Currents

Tungsten Diameter mm	DC Current Amps	AC Current Amps	AC Current Amps
	Torch Negative 2% Thoriated	Un-Balanced Wave 0.8% Zirconiated	Balanced Wave 0.8% Zirconiated
1.0mm	15-80	15-80	20-60
1.6mm	70-150	70-150	60-120
2.4mm	150-250	140-235	100-180
3.2mm	250-400	225-325	160-250
4.0mm	400-500	300-400	200-320

#### §4.2.5 Tungsten Preparation

Always use **DIAMOND** wheels when grinding and cutting. While tungsten is a very hard material, the surface of a diamond wheel is harder, and this makes for smooth grinding. Grinding without diamond wheels, such as Aluminum oxide wheels, can lead to jagged edges, imperfections, or poor surface finishes not visible to the eye that will contribute to weld inconsistency and weld defects.

Always ensure to grind the tungsten in a longitudinal direction on the grinding wheel. Tungsten electrodes are manufactured with the molecular structure of the grain running lengthwise and thus grinding crosswise is “grinding against the grain”. If electrodes are ground crosswise, the electrons have to jump across the grinding marks and the arc can start before the tip and wander. Grinding longitudinally with the grain, the electrons flow steadily and easily to the end of the tungsten tip. The arc starts straight and remains narrow, concentrated and stable.



## Electrode Shape & Angle

The shape of the tungsten electrode tip is an important process variable in precision arc welding. A good selection of tip/flat size will balance the need for several advantages. The bigger the flat, the more likely arc wander will occur and the more difficult it will be to arc start. However, increasing the flat to the maximum level that still allows arc start and eliminates arc wander will improve the weld penetration and increase the electrode life. The included angle determines weld bead shape and size. Generally, as the included angle increases, penetration increases and bead width decreases.

Some welders still grind electrodes to a sharp point, which makes arc starting easier. However, they risk decreased welding performance from melting at the tip.



## Electrode Included Angle/Taper - DC Welding

Tungsten electrodes for DC welding should be ground longitudinally and concentrically with diamond wheels to a specific included angle in conjunction with the tip/flat preparation. Different angles produce different arc shapes and offer different weld penetration capabilities.

### Blunter electrodes with larger included angle provide:

- Last Longer
- Have better weld penetration
- Have a narrower arc shape
- Can handle more amperage without eroding.



### Sharper electrodes with smaller included angle provide:

- Offer less arc weld
- Have a wider arc

- Have a more consistent arc

Tungsten Diameter	Diameter at the Tip - mm	Constant Included Angle - Degrees	Current Range Amps	Current Range Pulsed Amps
1.0mm	.250	20	05 - 30	05 - 60
1.6mm	.500	25	08 - 50	05 - 100
1.6mm	.800	30	10 - 70	10 - 140
2.4mm	.800	35	12 - 90	12 - 180
2.4mm	1.100	45	15 - 150	15 - 250
3.2mm	1.100	60	20 - 200	20 - 300
3.2mm	1.500	90	25 - 250	25 - 350

### §4.2.6 TIG Torch Switch Controls

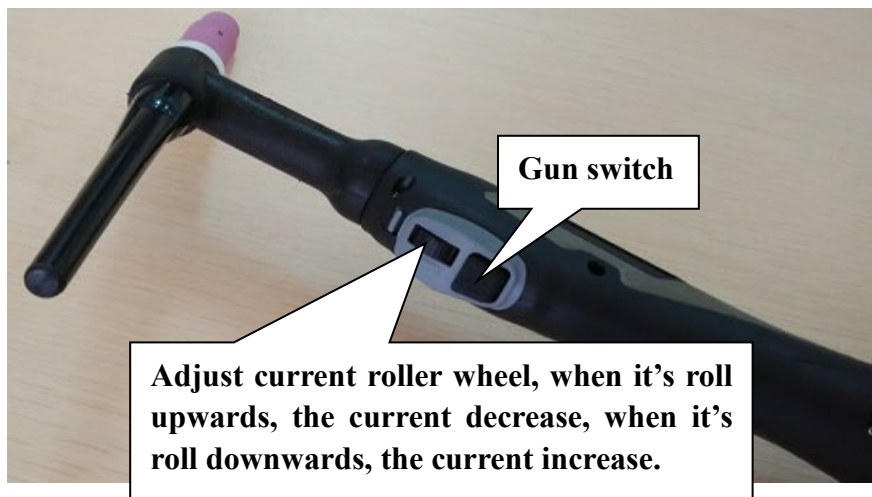

### 9 Pin Remote Plug Connection

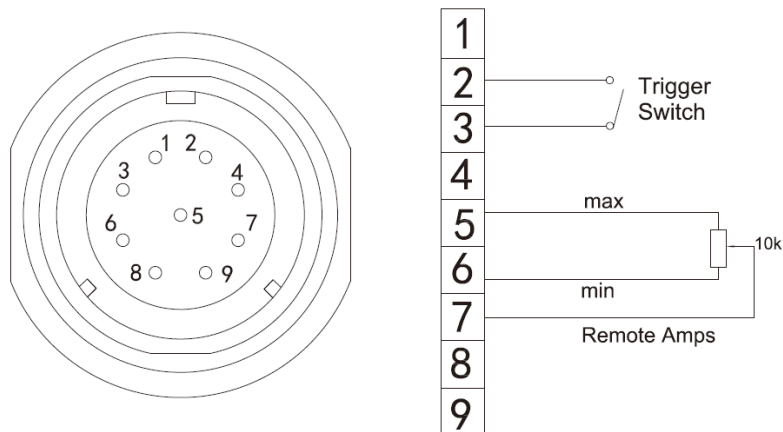

Socket Pin	Function
1	Not connected
2	Trigger Switch Input
3	Trigger Switch Input
4	Not connected
5	10k ohm (maximum) connection to 10k ohm remote control potentiometer
6	Zero ohm (minimum) connection to 10k ohm remote control potentiometer
7	Wiper arm connection to 10k ohm remote control potentiometer
8	Not connected
9	Not connected

## §4.3 Installation & Operation for MIG Welding

### §4.3.1 Set up installation for MIG Welding

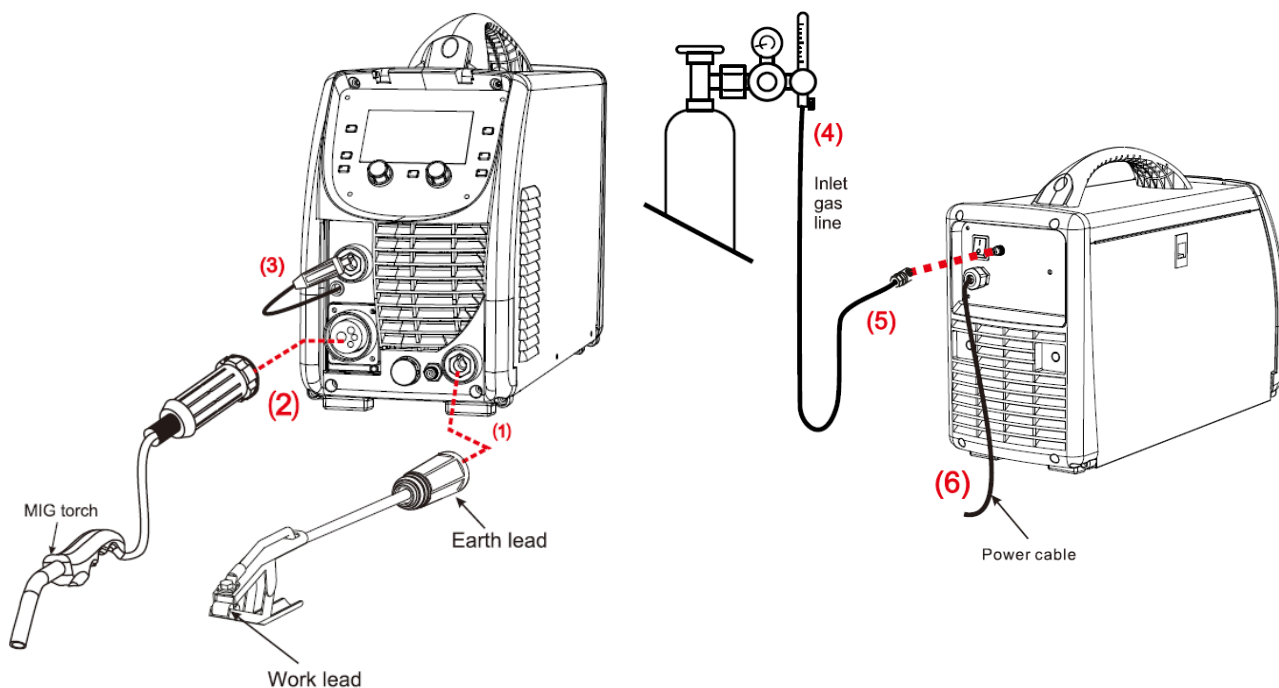

- (1) Insert the earth cable plug into the Negative (-) socket and twist to tighten.
- (2) Plug the MIG welding gun into MIG torch euro-connector on the front panel and tighten locking nut securely.
- (3) Insert the polarity switch cable plug into the positive socket on the front of the machine and tighten it.
- (4) Connect the gas regulator to the gas cylinder and connect the gas line to the regulator.
- (5) Connect the gas line to gas connector on the rear panel.
- (6) Connect the power cord of welding machine with the outlet on electrical box.

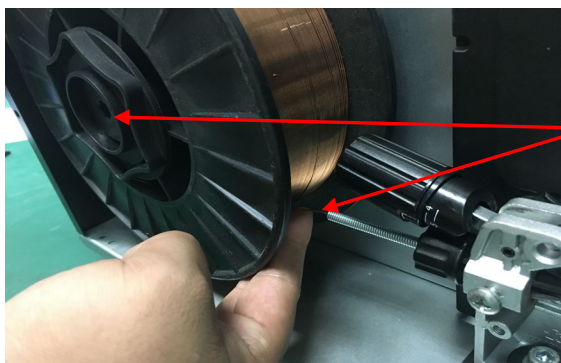

- (7) Place wire onto spool holder - (spool retaining nut is left hand thread) Feed wire through the inlet guide tube on to the drive roller.

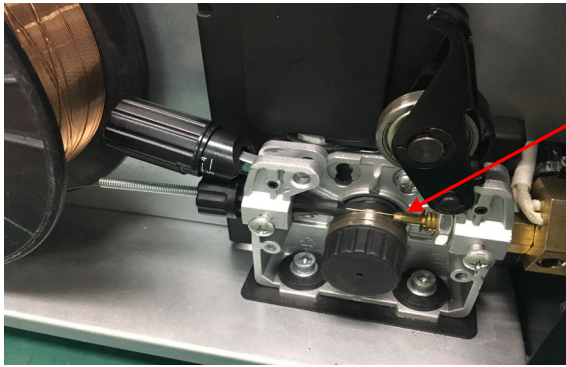

(8) Feed wire over drive roller into outlet guide wire tube, push wire through approximately 150mm.

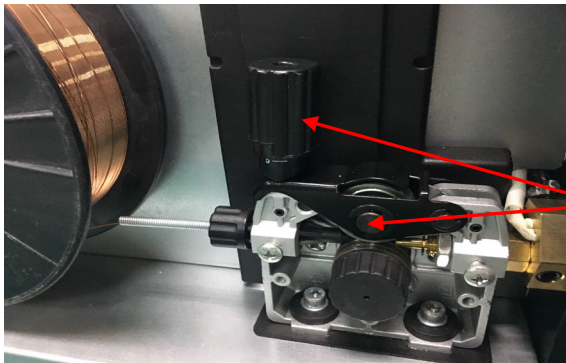

(9) Close down the top roller bracket and clip the pressure arm into place with a medium amount of pressure applied.

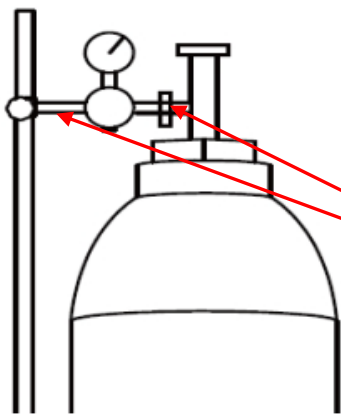

(10) Carefully open the valve of the gas cylinder, set the required gas flow rate.

- (11) Remove the gas nozzle and contact tip from the torch neck.
- (12) Press and hold the manual wire button to feed the wire through to the torch neck, release the manual wire button when the wire exits the torch neck.
- (13) Fit the correct sized contact tip and feed the wire through it, screw the contact tip into the tip holder of the torch neck and nip it up tightly.
- (14) Fit the gas nozzle to the torch head.
- (15) Carefully open the gas cylinder valve, set the required gas flow rate on the regulator.
- (16) Select the desired MIG function, Select program number to suit the wire diameter and gas type being used as shown on the display.
- (17) Select torch switch mode: 2T/ 4T/ Spot weld.

(18) Set the required welding parameters to suit the material thickness being welded.

### §4.3.2 Wire Feed Roller Selection

The importance of smooth consistent wire feeding during MIG welding cannot be emphasized enough. Simply put the smoother the wire feed then the better the weld.

Feed rollers or drive rollers are used to feed the wire mechanically through the length of the welding gun cable. Feed rollers are designed to be used for certain types of welding wire and they have different types of grooves machined in them to accommodate the different types of wire. The wire is held in the groove by the top roller of the wire drive unit and is referred to as the pressure roller, pressure is applied by a tension arm that can be adjusted to increase or decrease the pressure as required. The type of wire will determine how much pressure can be applied and what type of drive roller is best suited to obtain optimum wire feed.

**Solid Hard Wire** - like Steel, Stainless Steel requires a drive roller with a “V” shape groove for optimum grip and drive capability. Solid wires can have more tension applied to the wire from the top pressure roller that holds the wire in the groove and the “V” shape groove is more suited for this. Solid wires are more forgiving to feed due to their higher cross-sectional column strength, they are stiffer and don’t deflect so easily.

**Soft Wire** – Such as aluminum, require a “U” shape groove. Aluminum wire has a lot less column strength, can bend easily and is therefore more difficult to feed. Soft wires can easily buckle at the wire feeder where the wire is fed into inlet guide tube of the torch. The U-shaped roller offers more surface area grip and traction to help feed the softer wire. Softer wires also require less tension from the top pressure roller to avoid deforming the shape of the wire, too much tension will push the wire out of shape and cause it to catch in the contact tip.

**Flux Core/ Gasless Wire** - These wires are made up of a thin metal sheath that has flux and metal compounds layered onto the surface and then rolled into a cylinder to form the finished wire. The wire cannot take too much pressure from the top roller as it can be crushed and deformed if too much pressure is applied. A knurled-V drive roller has been developed and it has small serrations in the groove, the serrations grip the wire and

assist to drive it without too much pressure from the top roller. The down side to the knurled wire feed roller on flux cored wire is it will slowly over time bit by bit eat away at the surface of the welding wire, and these small pieces will eventually go down into the liner. This will cause clogging in the liner and added friction that will lead to welding wire feed problems. A U groove wire can also be used for flux core wire without the wire particles coming off the wire surface. However, it is considered that the knurled roller will give a more positive feed of flux core wire without any deformation of the wire shape.

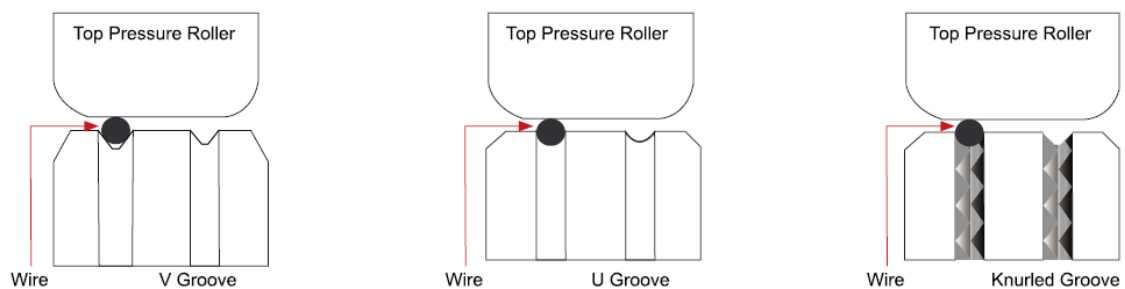

### §4.3.3 Wire Installation and Set-Up Guide

Again the importance of smooth consistent wire feeding during MIG welding cannot be emphasized enough. The correct installation of the wire spool and the wire into the wire feed unit is critical to achieving an even and consistent wire feed. A high percentage of faults with MIG welders emanate from poor set up of the wire into the wire feeder. The guide below will assist in the correct setup of your wire feeder.

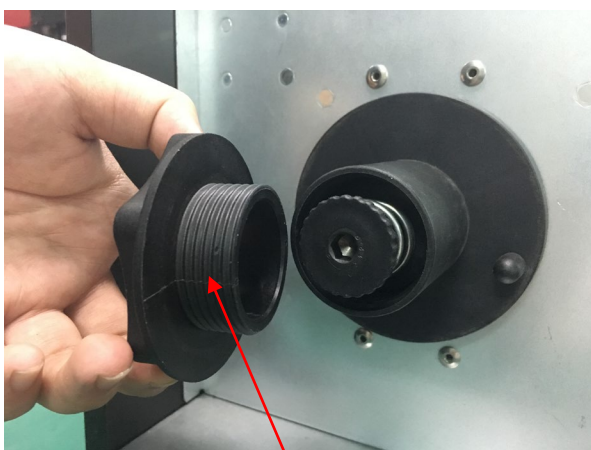

(1) Remove the spool retaining nut.

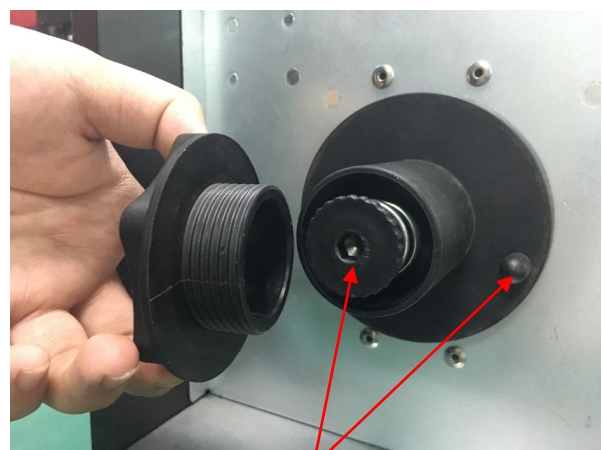

(2) Note the tension spring adjuster and spool locating pin.

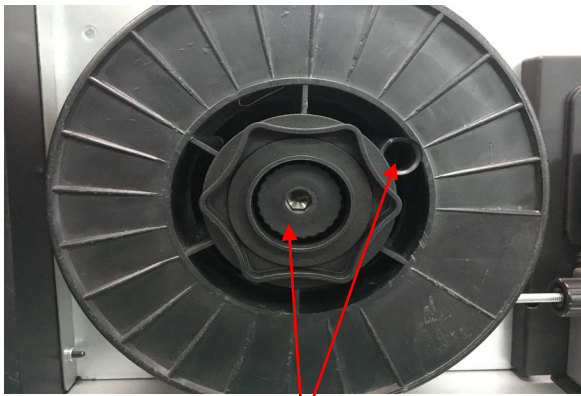

(3) Fit the wire spool onto the spool holder fitting the locating pin into the location hole on the spool. Replace the spool retaining nut tightly.

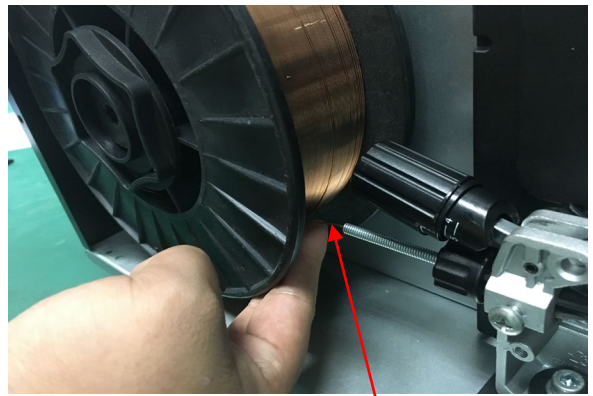

(4) Snip the wire carefully, be sure to hold the wire to prevent the spool uncoiling. Carefully feed the wire into the inlet guide tube of the wire feed unit.

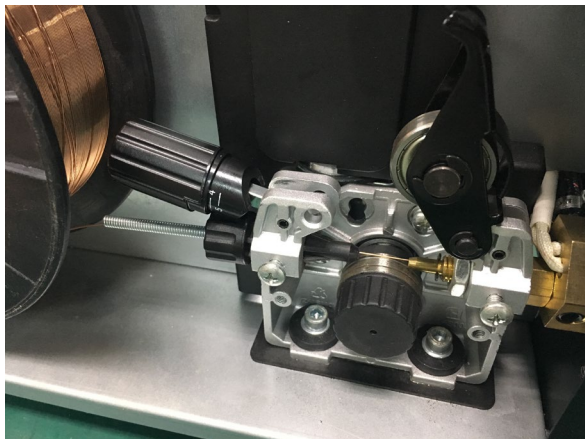

(5) Feed the wire through the drive roller and into the outlet guide tube of the wire feeder.

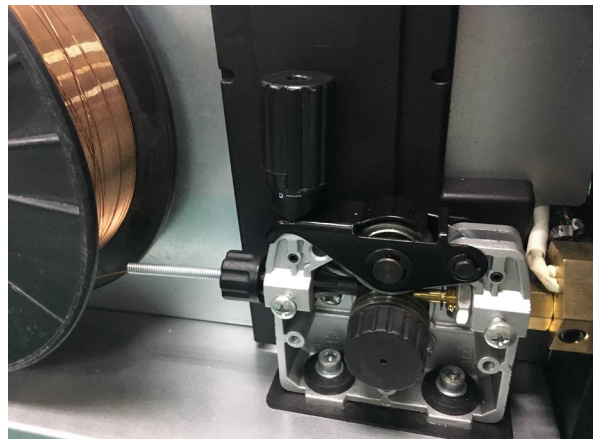

(6) Lock down the top pressure roller and apply a medium amount of pressure using the tension adjustment knob.

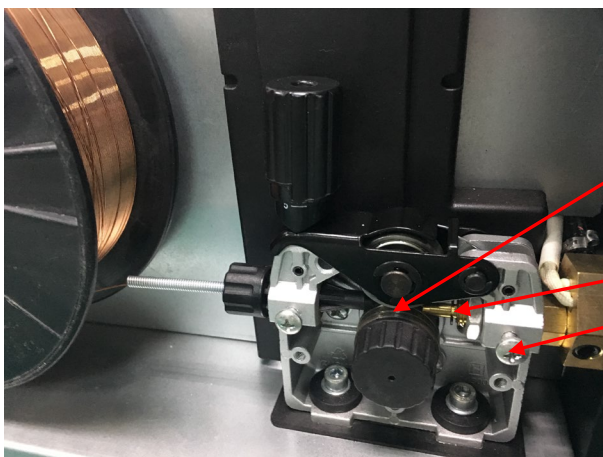

(7) Check that the wire passes through the center of the outlet guide tube without touching the sides. Loosen the locking screw and then loosen the outlet guide tube retaining nut too make adjustment if required. Carefully retighten the locking nut and screw to hold the new position.



(8) A simple check for the correct drive tension is to bend the end of the wire over hold it about 100mm from your hand and let it run into your hand, it should coil round in your hand without stopping and slipping at the drive rollers, increase the tension if it slips.

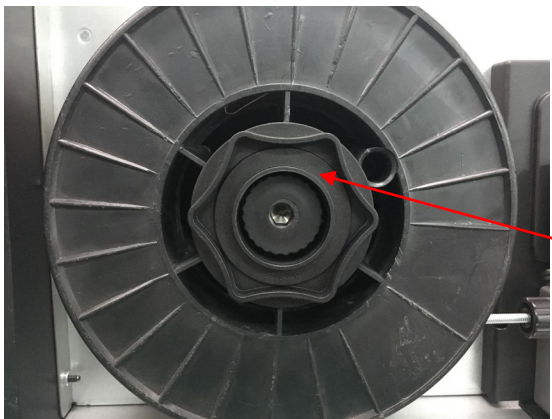

(9) The weight and speed of the wire spool turning creates an inertia that can cause the spool to run on and the wire loop over the side of the spool and tangle. If this happens increase the pressure on the tension spring inside the spool holder assembly using the tension adjustment screw.

#### §4.3.4 MIG Torch Liner Types and Information

##### MIG Torch Liners

The liner is both one of the simplest and most important components of a MIG gun. Its sole purpose is to guide the welding wire from the wire feeder, through the gun cable and up to the contact tip.

##### Steel Liners

Most MIG gun liners are made from coiled steel wire also known as piano wire, which provides the liner with good rigidity and flexibility and allows it to guide the welding wire smoothly through the welding cable as it bends and flex during operational use. Steel liners are primarily used for feeding of solid steel wire, other wires such as Aluminum, Silicon Bronze, Etc. will perform better using a Teflon or Polyamide line. The internal diameter of the liner is important and relative to the wire diameter being used. The

correct inside diameter and will assist in smooth feeding and prevention of the wire kinking and bird-nesting at the drive rollers. Also bending the cable too tightly during welding increases the friction between the liner and the welding wire making it more difficult to push the wire through the liner resulting in poor wire feeding, premature liner wear and bird-nesting. Dust, grime and metal particles can accumulate inside the liner over time and cause friction and blockages, it is recommended to periodically blow out the liner with compressed air. Small diameter welding wires, 0.6mm through 1.0mm have relatively low columnar strength, and if matched with an oversized liner, can cause the wire to wander or drift within the liner. This in turn leads to poor wire feeding and premature liner failure due to excessive wear. By contrast, larger diameter welding wires, 1.2mm through 2.4mm have much higher columnar strength but it is important to make sure the liner has enough internal diameter clearance. Most manufacturers will produce liners sized to match wire diameters and length of welding torch cable and most are color coded to suit.

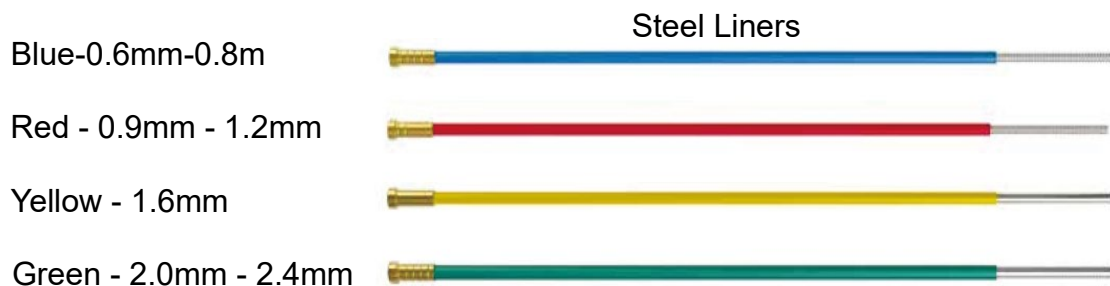

### **Teflon and Polyamide (PA) Liners**

Teflon liners are well suited for feeding soft wires with poor column strength like aluminum wires. The interiors of these liners are smooth and provide stable feeding, especially on small diameter welding wire Teflon can be good for higher heat applications that utilize water-cooled torches and brass neck liners. Teflon has good abrasion resistance characteristics and can be used with a variety of wire types such as silicon bronze, stainless steel as well as aluminum. A note of caution to carefully inspect the end of the welding wire prior to feeding it down the liner. Sharp edges and burrs can score the inside of the liner and lead to blockages and accelerated wear. Polyamide Liners (PA) are made of carbon infused nylon and are ideal for softer aluminum, copper alloy welding wires and push pull torch applications. These liners are generally fitted with

a floating collet to allow the liner to be inserted all the way to the feed rollers.

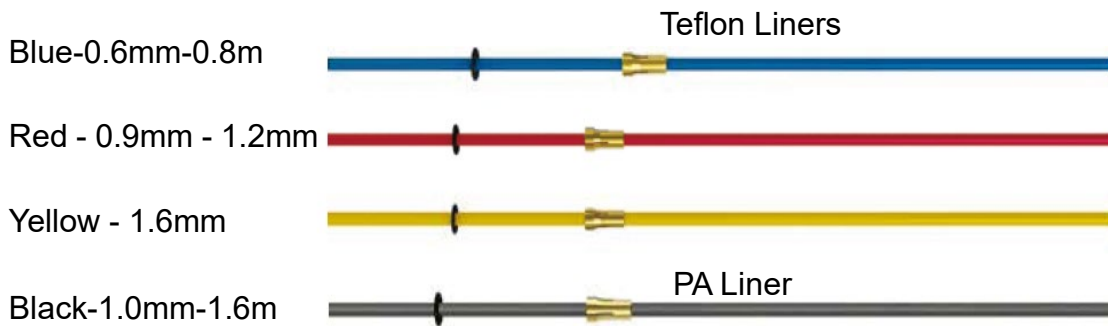

### Copper - Brass Neck Liners

For high heat applications fitting brass or copper wound jumper or neck liner on the end of the liner at the neck end will increase the working temperature of the liner as well as improve the electrical conductivity of the welding power transfer to the wire. It is recommended for all Aluminum and Silicone Bronze welding applications.



### §4.3.5 Torch & Wire Feed Set-Up for Aluminum Wire

The same method is used for Teflon and/or Polyamide Liners (PA).

### §4.3.6 MIG Welding

#### Definition of MIG Welding

MIG (metal inert gas) welding also known as GMAW (gas metal arc welding) or MAG (metal active gas welding), is a semi-automatic or automatic arc welding process in which a continuous and consumable wire electrode and a shielding gas are fed through a welding gun. A constant voltage, direct current power source is most commonly used with MIG welding. There are four primary methods of metal transfer in MIG welding, called short circuit (also known as dip transfer) globular transfer, spray transfer and pulsed-spray, each of which has distinct properties and corresponding advantages and limitations.

**Short Circuit Transfer** - Short circuit transfer is the most common used method whereby the wire electrode is fed continuously down the welding torch through to and

exiting the contact tip. The wire touches the work piece and causes a short circuit the wire heats up and begins to form a molten bead, the bead separates from the end of the wire and forms a droplet that is transferred into the weld pool. This process is repeated about 100 times per second, making the arc appear constant to the human eye.

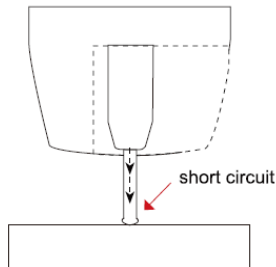

The wire touches the work creating a short circuit. Because there is no space between the wire and the base metal there is no arc.

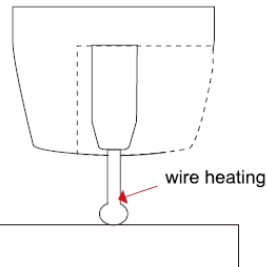

The wire cannot support all the current flow so resistance builds up and the wire begins to melt.

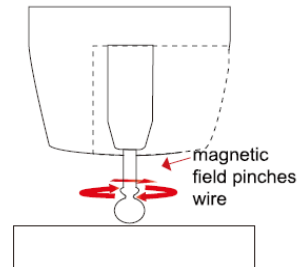

The current flow creates a magnetic field that begins to pinch the melting wire forming it into droplet.

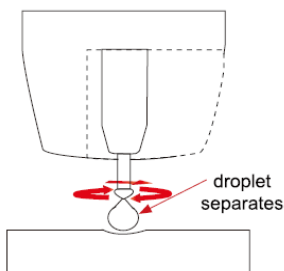

The pinch causes the forming droplet to separate and falls towards the now creating weld pool.

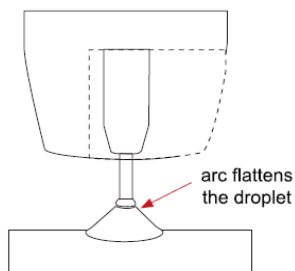

An arc is created at the separation of the droplet and the heat and force of the arc flattens-out the droplet into the weld pool.

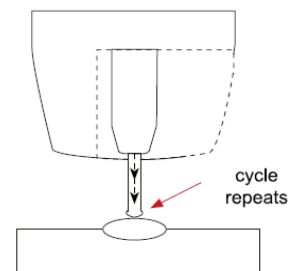

The wire feed speed overcomes the heat of the arc and the wire again approaches the work to short circuit and repeat the cycle.

### Basic MIG Welding

Good weld quality and weld profile depends on gun angle, direction of travel, electrode extension (stick out), travel speed, thickness of base metal, wire feed speed and arc voltage. To follow are some basic guides to assist with your setup.

**Gun Position - Travel Direction, Work Angle:** Gun position or technique usually refers to how the wire is directed at the base metal, the angle and travel direction chosen. Travel speed and work angle will determine the characteristic of the weld bead profile and degree of weld penetration.

**Push Technique** - The wire is located at the leading edge of the weld pool and pushed towards the un-melted work surface. This technique offers a better view of the weld joint

and direction of the wire into the weld joint. Push technique directs the heat away from the weld puddle allowing faster travel speeds providing a flatter weld profile with light penetration - useful for welding thin materials. The welds are wider and flatter allowing for minimal clean-up and grinding time.

**Perpendicular Technique** - The wire is fed directly into the weld, this technique is used primarily for automated situations or when conditions make it necessary. The weld profile is generally taller and a deeper penetration is achieved.

**Drag Technique** - The gun and wire are dragged away from the weld bead. The arc and heat is concentrated on the weld pool, the base metal receives more heat, deeper melting, more penetration and the weld profile is higher with more build up.

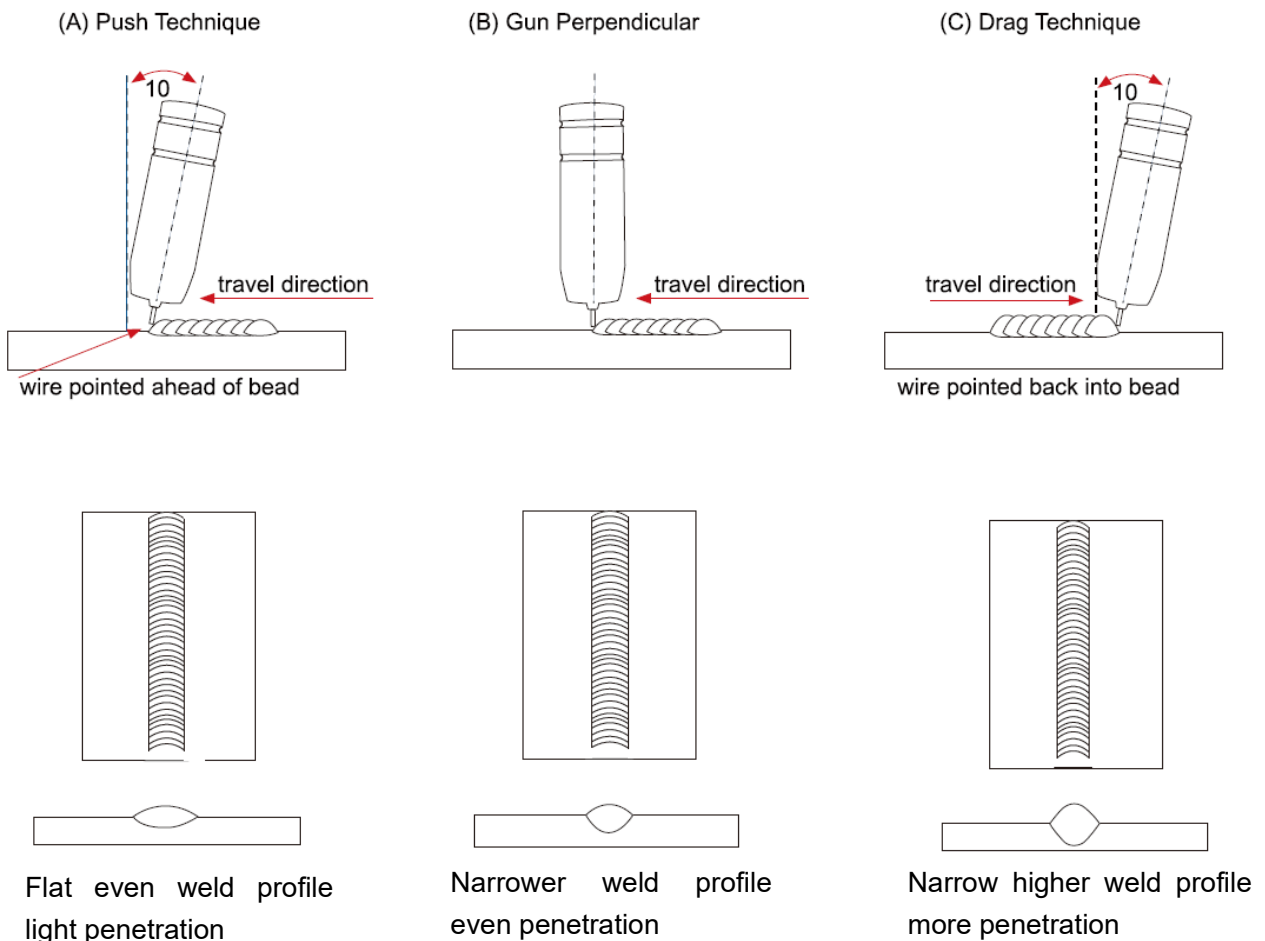

**Travel Angle** - Travel angle is the right to left angle relative to the direction of welding. A travel angle of  $5^{\circ}$  ~  $15^{\circ}$  is ideal and produces a good level of control over the weld pool. A travel angle greater than  $20^{\circ}$  will give an unstable arc condition with poor weld metal transfer, less penetration, high levels of spatter, poor gas shield and poor quality finished weld.

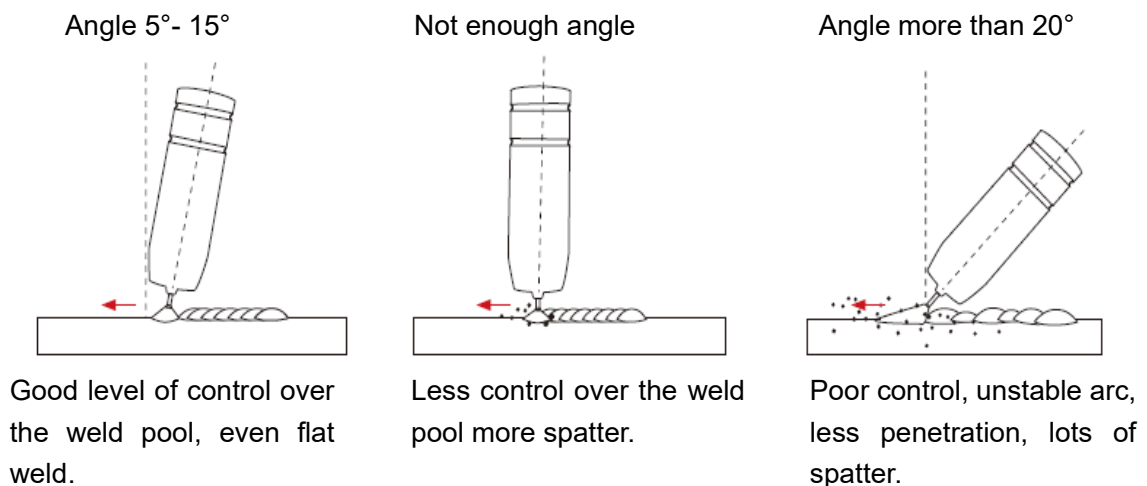

**Angle to Work** - The work angle is the forward back angle of the gun relative to the work piece. The correct work angle provides good bead shape, prevents undercut, uneven penetration, poor gas shield and poor quality finished weld.

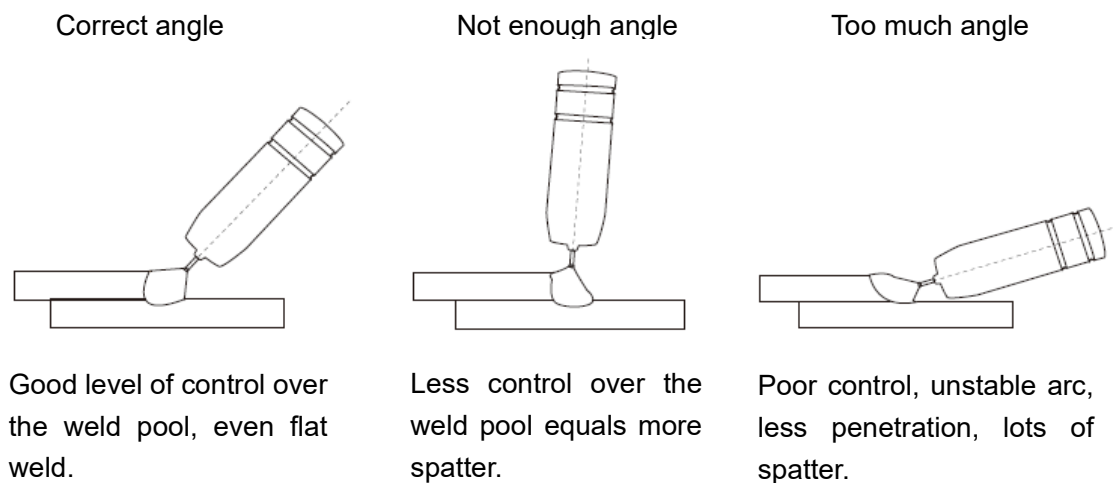

**Stick Out**- Stick out is the length of the un-melted wire protruding from the end of the contact tip. A constant even stick out of 5-10mm will produce a stable arc, and an even current flow providing good penetration and even fusion. Too short stick out will cause an unstable weld pool, produce spatter and over heat the contact tip. Too long stick out will cause an unstable arc, lack of penetration, lack of fusion and increase spatter.

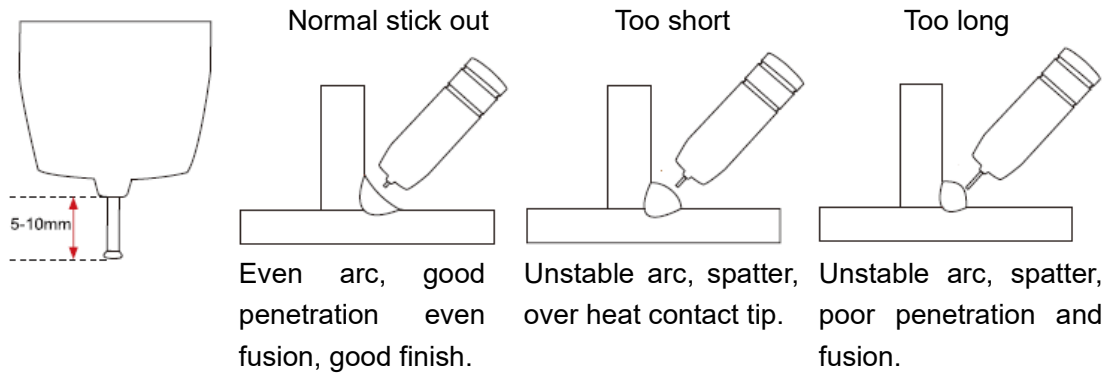

**Travel Speed** - Travel speed is the rate that the gun is moved along the weld joint and is usually measured in inches per minute (IPM). Travel speeds can vary depending on conditions and the welder's skill and is limited to the welder's ability to control the weld pool. Push technique allows faster travel speeds than drag technique. Gas flow must also correspond with the travel speed, increasing with faster travel speed and decreasing with slower speed. Travel speed needs to match the amperage and will decrease as the material thickness and amperage increase.

**Too Fast Travel Speed** - A too fast travel speed produces too little heat per mm of travel resulting in less penetration and reduced weld fusion, the weld bead solidifies very quickly trapping gases inside the weld metal causing porosity. Undercutting of the base metal can also occur and an unfilled groove in the base metal is created when the travel speed is too fast to allow molten metal to flow into the weld crater created by the arc heat.

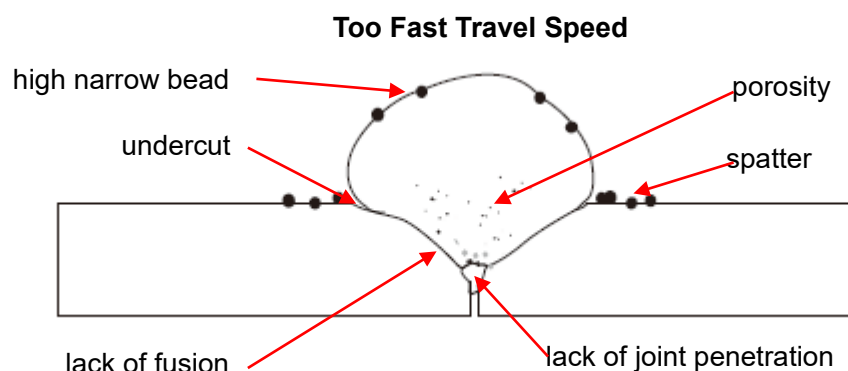

**Too Slow Travel Speed** - A too slow travel speed produces a large weld with lack of penetration and fusion. The energy from the arc dwells on top of the weld pool rather than penetrating the base metal. This produces a wider weld bead with more deposited

weld metal per mm than is required resulting in a weld deposit of poor quality.

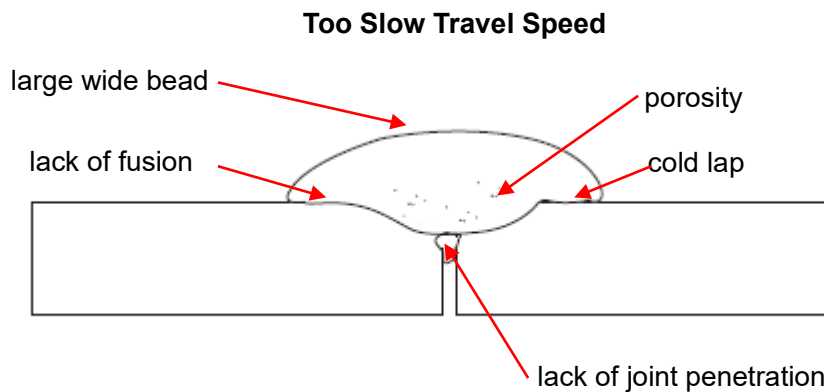

**Correct Travel Speed** - The correct travel speed keeps the arc at the leading edge of the weld pool allowing the base metal to melt sufficiently to create good penetration, fusion and wetting out of the weld pool producing a weld deposit of good quality.

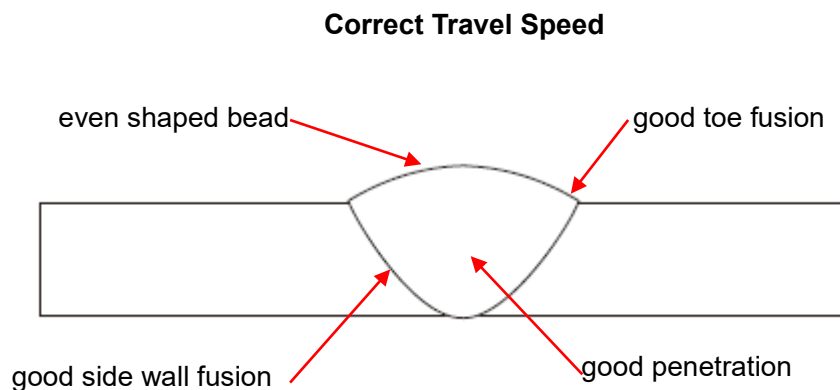

**Gas selection** - The purpose of the gas in the MIG process is to protect / shield the wire, the arc and the molten weld metal from the atmosphere. Most metals when heated to a molten state will react with the air in the atmosphere, without the protection of the shielding gas the weld produced would contain defects like porosity, lack of fusion and slag inclusions.

The correct gas flow is also very important in protecting the welding zone from the atmosphere.

Use the correct shielding gas. CO<sub>2</sub> is good for steel and offers good penetration, the weld profile is narrower and slightly more raised than the weld profile obtained from Argon/CO<sub>2</sub> mixed gas. Argon CO<sub>2</sub> (Argon 80% & CO<sub>2</sub> 20%) mix gas offers better weld ability for thin metals and has a wider range of setting tolerance on the machine.

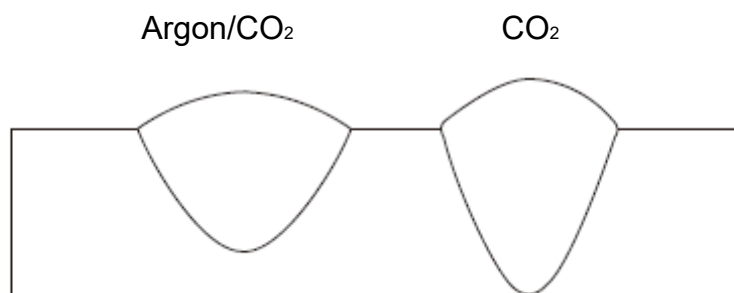

Penetration Pattern for Steel

Argon gas at 100% mixture is good for aluminum and silicone bronze applications. It offers good penetration and weld control. CO<sub>2</sub> is not recommended for these metal alloys.

**Wire types and sizes** - Use the correct wire type for the base metal being welded. Use stainless steel wire for stainless steel, aluminum for aluminum and steel wires for steel. Use a smaller diameter wire for thin base metals. For thicker materials use a larger wire diameter and larger machine, check the recommended welding capability of your machine. As a guide refer to the “Welding Wire Thickness Chart” below.

WELDING WIRE DIAMETER CHART					
MATERIAL THICKNESS	RECOMMENDED WIRE DIAMETERS				
	0.8	0.9	1.0	1.2	1.6
0.8mm	Yellow				
0.9mm	Yellow				
1.0mm	Yellow	Yellow			
1.2mm	Yellow	Yellow			
1.6mm	Yellow	Yellow			
2.0mm	Yellow	Yellow	Yellow		
2.5mm	Yellow	Yellow	Yellow	Yellow	
3.0mm	Yellow	Yellow	Yellow	Yellow	Yellow
4.0mm	Yellow	Yellow	Yellow	Yellow	Yellow
5.0mm	Yellow	Yellow	Yellow	Yellow	Yellow
6.0mm	Yellow	Yellow	Yellow	Yellow	Yellow
8.0mm		Yellow	Yellow	Yellow	Yellow
10mm			Yellow	Yellow	Yellow
14mm			Yellow	Yellow	Yellow
18mm				Yellow	Yellow
22mm					Yellow
					Yellow

For material thickness of 5.0mm and greater, multi-pass runs or a beveled joint design may be required depending on the amperage capability of your machine.

## §4.4 Installation & Operation for Spool Gun

### §4.4.1 Set up installation for Spool Gun

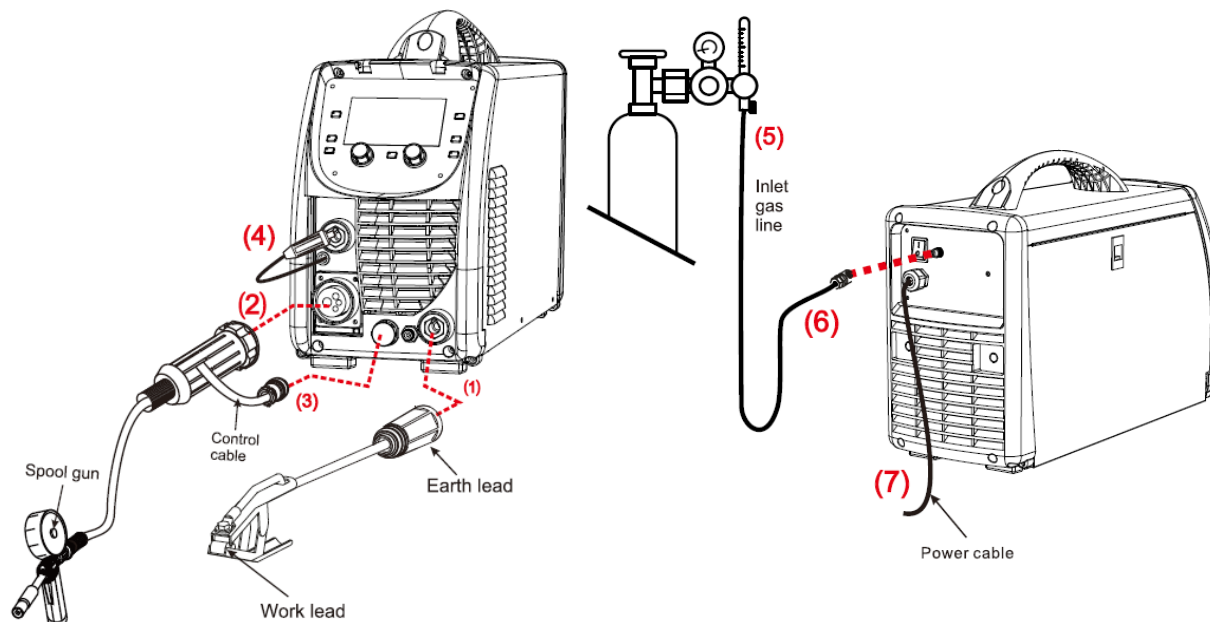

(1) Insert the earth cable plug into the negative (-) socket on the front of the machine and twist to tighten.

(2) Plug the Spool Gun into the euro-connect socket on the front panel and tighten.

**IMPORTANT: When connecting the torch be sure to tighten the adaptor nut completely tight. A loose connection can result in arcing between the gun and machine connector and that causes serious damage to both the torch and machine connections.**

(3) Connect the Spool Gun control cable to the 9-pin receptacle on the front of the machine.

(4) Insert the polarity switching cable plug into the positive socket on the front of the machine and tighten it.

(5) Connect the gas regulator to the gas cylinder and connect the gas line to the regulator.

(6) Connect the gas line to gas connector on the rear panel.

(7) Connect the power cord of welding machine with the outlet on electrical box.



(8) Remove the spool cover by pressing button and lifting off the cover.

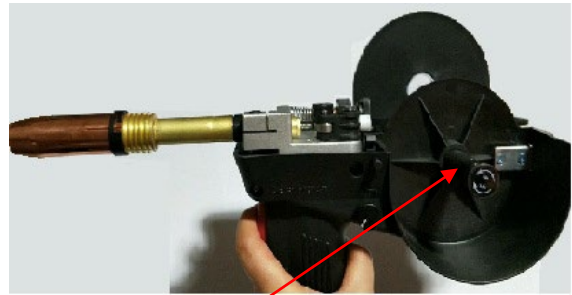

(9) Place a spool of wire inside the spool holder on post.

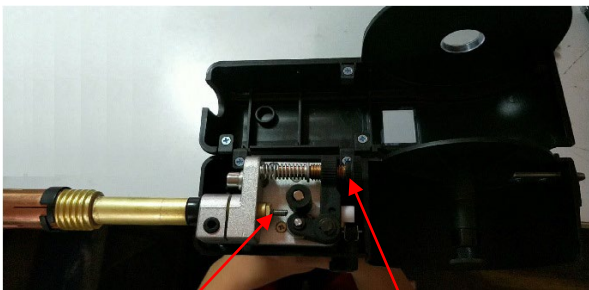

(10) Feed the wire through the drive rolls and into the inlet guide tube. Tighten the wire tension swing arm.



(11) Pull the trigger to drive the wire down the neck until it exits the contact tip.

(12) Carefully open the gas cylinder valve and set the required gas flow rate.

(13) Set welding parameters using the knobs as shown on digital displays.

## §4.4.2 Spool Gun Control

### 226 Spool Gun

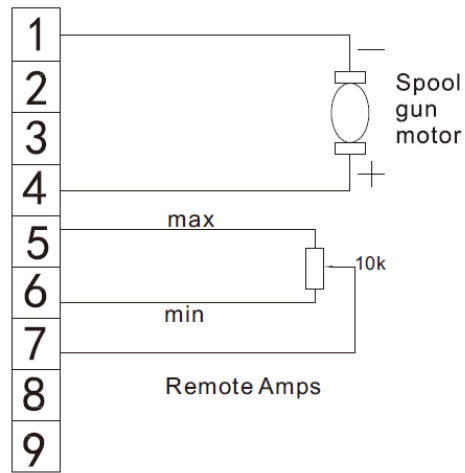
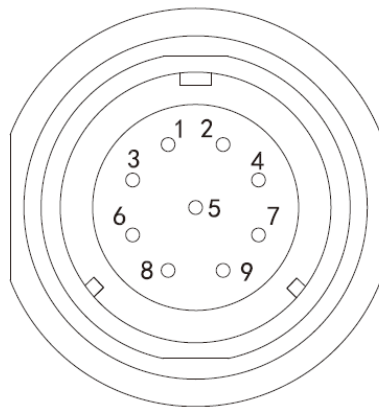
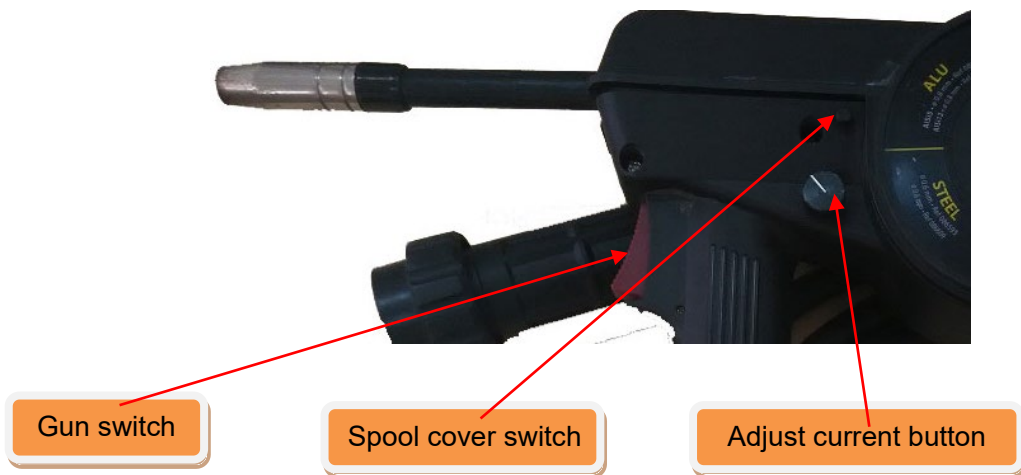

Remote Control Socket

Socket Pin	Function
1	Spool gun motor
2	Not connected
3	Not connected
4	Spool gun motor
5	10k ohm (maximum) connection to 10k ohm remote control potentiometer.
6	Zero ohm (minimum) connection to 10k ohm remote control potentiometer.
7	Wiper arm connection to 10k ohm remote control potentiometer.
8	Not connected
9	Not connected

## §4.5 Welding Parameters

### Process reference for CO<sub>2</sub> butt welding of low carbon steel solid welding wire

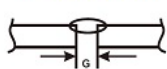
	Material thickness (MM)	Root gap G(MM)	Wire diameter (MM)	Welding current (A)	Welding voltage (V)	Welding speed (CM/MIN)	Gas-flow rate (L/MIN)
Butt-joint 	0.8	0	0.8	60-70	16-16.5	50-60	10
	1.0	0	0.8	75-85	17-17.5	50-60	10-15
	1.2	0	0.8	80-90	17-18	50-60	10-15
	2.0	0-0.5	1.0/1.2	110-120	19-19.5	45-50	10-15
	3.2	0-1.5	1.2	130-150	20-23	30-40	10-20
	4.5	0-1.5	1.2	150-180	21-23	30-35	10-20
	6	0	1.2	270-300	27-30	60-70	10-20
	6	1.2-1.5	1.2	230-260	24-26	40-50	15-20

### Process reference for CO<sub>2</sub> corner welding of low carbon steel solid welding wire

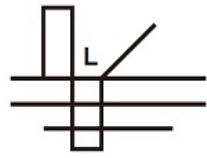
	Material thickness (MM)	Wire diameter (MM)	Welding current (A)	Welding voltage (V)	Welding speed (CM/MIN)	Gas-flow rate (L/MIN)
Corner joint 	1.0	0.8	70-80	17-18	50-60	10-15
	1.2	1.0	85-90	18-19	50-60	10-15
	1.6	1.0/1.2	100-110	18-19.5	50-60	10-15
	1.6	1.2	120-130	19-20	40-50	10-20
	2.0	1.0/1.2	115-125	19.5-20	50-60	10-15
	3.2	1.0/1.2	150-170	21-22	45-50	15-20
	3.2	1.2	200-250	24-26	45-60	10-20
	4.5	1.0/1.2	180-200	23-24	40-45	15-20
	4.5	1.2	200-250	24-26	40-50	15-20
	6	1.2	220-250	25-27	35-45	15-20
	6	1.2	270-300	28-31	60-70	15-20
	8	1.2	270-300	28-31	60-70	15-20
	8	1.2	260-300	26-32	25-35	15-20
	8	1.6	300-330	25-26	30-35	15-20
	12	1.2	260-300	26-32	25-35	15-20

## §4.6 Operation Environment

- ▲ Height above sea level  $\leq 1000$  M.
- ▲ Operation temperature range 14 ~ 104°F (-10 ~ +40°C).
- ▲ Air relative humidity is below 90%.
- ▲ Preferable site the machine some angles above the floor level does not exceed 15°.
- ▲ Protect the machine against high moisture, water and against direct sunshine.
- ▲ Take care that there is sufficient ventilation during welding. There must be at least 1-1/2" (38cm) free distance between the machine and wall.

## §4.7 Operation Notices

- ▲ Read Section §1 carefully before starting to use this equipment.
- ▲ Ensure that the input is 110V/230V AC, single-phase: 50/60Hz.
- ▲ Before operation, clear the working area. Do not watch the arc in unprotected eyes.
- ▲ Ensure good ventilation of the machine to improve duty cycle and life.
- ▲ Turn off power supply when the operation finished for energy consumption efficiency.
- ▲ When power switch shuts off protectively because of failure. Don't restart it until problem has been resolved. Otherwise, permanent damage could occur.
- ▲ In case of problems, contact your local dealer.

# §5 Diagram for Guns

## §5.1 MIG Torch



The starting point for professional welding.

Main characteristics:

- interchangeable with the best-known European brands
- ergonomic handle
- front and rear cable protection spring
- articulation to ease cable bending
- attachments: Euro mobile pins

All the above names and trademarks are of exclusive property of the respective companies.

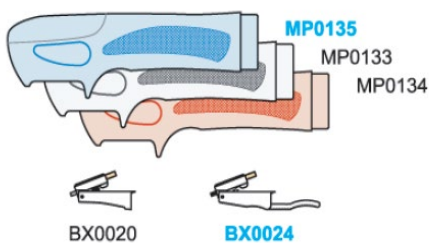
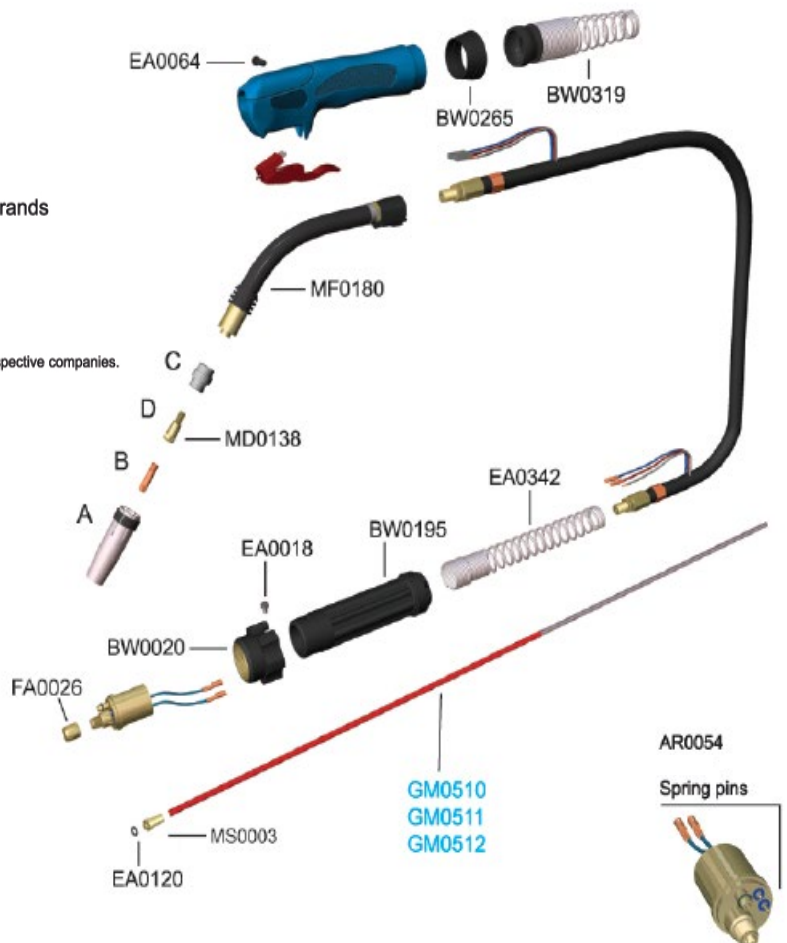
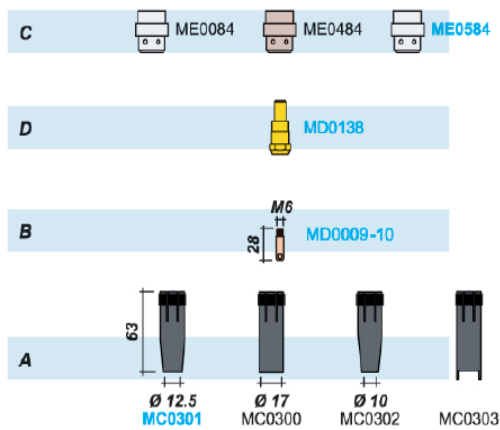

DIAGRAM FOR GUNS



TECHNICAL DATA

	Voltage class	L
	Cooling	Air cooling
	Wire Ømm	0.8 • 0.9 • 1.0 • 1.2
	Duty cycle 60%	250A, CO, 220A

Part No	Description	Pack
MA7143	Mig ERGOPLUS 24 torch 3m with spring pins	1
MA7144	Mig ERGOPLUS 24 torch 4m with spring pins	1
MA7145	Mig ERGOPLUS 24 torch 5m with spring pins	1

Part No	Description	Pack
AR0054	Euro Central Adaptor Boby	1
BW0020	Gun Plug Nut	1
BW0195	Back box hole 14	1
BW0265	Husing for handle	1
BX0020	Tigger	1
BX0024	Long Tigger	5
BX0067	Microswitch	5
BX0068	Microswitch	5
EA0018	Screw	5
EA0064	Screw	5
EA0087	Nut	5
EA0128	O-ring	1
EA0210	O-ring	1
EA0342	PLUS 15 Torch head	1
FA0026	Liner Nut	1
GM0510	Insulated Liner 1.0-1.2 Red	1
GM0511	Insulated Liner 1.0-1.2 Red	1
GM0512	Insulated Liner 1.0-1.2 Red 5m	1
GM0600	Teflon@ Liner 4.0*1.5, Blue 3m	1
GM0601	Teflon@ Liner 4.0*1.5, Blue 4m	1
GM0602	Teflon@ Liner 4.0*1.5, Blue	1
MC0300	Cylindrical Gas Nozzle $\phi$ 17	1
MC0301	Conical Gas Nozzle $\phi$ 12.5	1
MC0302	Conical Gas Nozzle $\phi$ 10	1
MC0303	Spot Welding Gas Nozzle $\phi$ 16	1
MD0009-06	Contact tip $\phi$ 0.6	2
MD0009-08	Contact tip $\phi$ 0.8	2
MD0009-09	Contact tip $\phi$ 0.9	2
MD0009-10	Contact tip $\phi$ 1.0	2
MD0009-12	Contact tip $\phi$ 1.2	2
MD0138	Tip Holder M6	1
ME0084	Gas diffuser PLUS 24	1
ME0484	Brown plastic gas diffuser PLUS	1
ME0584	White ceramic gas diffuser PLUS	1
MF0180	Torch Head PLUS 24	1
MP0133	Handle black ERGOPLUS	1
MP0134	Handle red ERGOPLUS	1
MP0135	Handle blue ERGOPLUS	1
MQ0129	Insulator	1
MS0003	Collet for Teflon Liner $\phi$ 4.0	5

## §5.2 TIG Torch

### PRO26 and PRO26FX

#### Air Cooled Pro-Grip® TIG Welding Torch

200A DC, 150A AC @ 60% Duty Cycle, EN60974-7 .020"-5/32" / 0.5mm to 4.0mm Electrodes

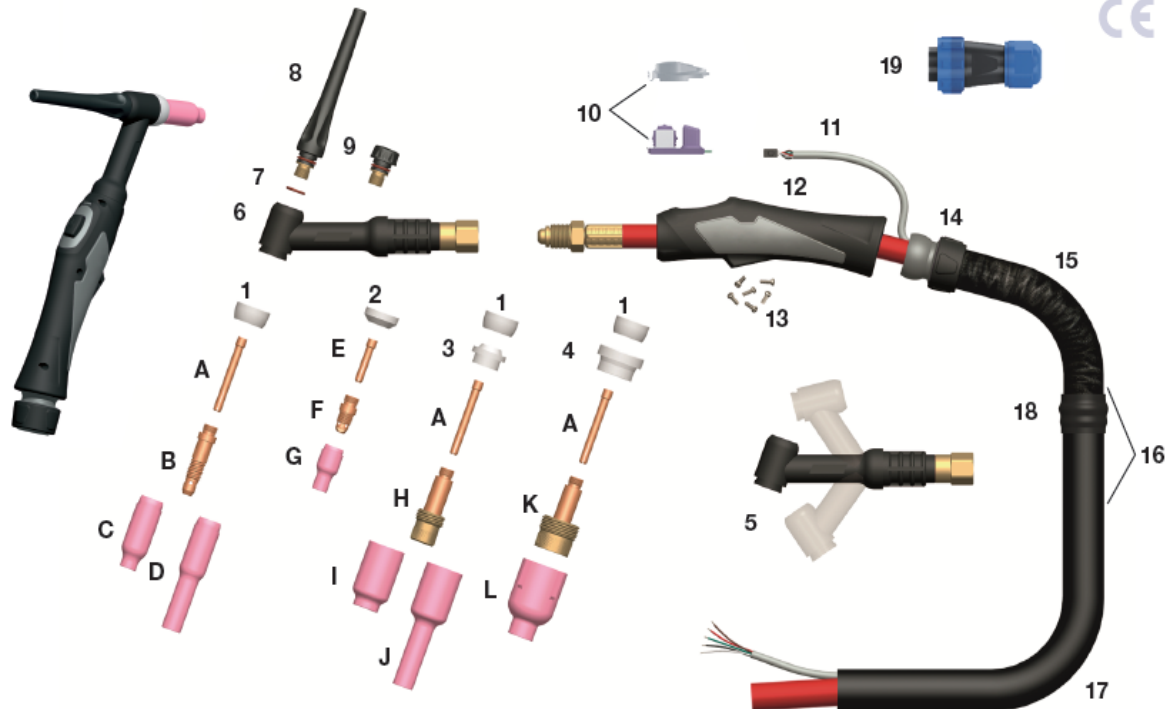

**TO ORDER A Pro-Grip® TIG TORCH PACKAGE PLEASE USE THE 5 STAGE PROCESS OUTLINED ON PAGE 128.**

Example:- PRO26FX-25S1BG0. PRO26FX Pro-Grip® Torch x 12.5ft with momentary switch, 3/8 BSP fittings and 2 Pin Amphenol Plug.

#### Torch Head

Stock Code	Description
PRO26	Torch Head Air Cooled 200A DC
PRO26FX	Torch Flexible Head Air Cooled 200A DC

#### Cable Length

Stock Code	Description
12	Cable c/w Leather Cover, Neoprene Sheath 12.5ft (4m)
25	Cable c/w Leather Cover, Neoprene Sheath 25ft (8m)

#### Switch Option

Stock Code	Description
S1	Momentary Switch
S1L	Momentary Switch and Lever
S2	2 Button Momentary
S3	3 Button Momentary
S4	4 Switch Momentary Rocker Kit
1K	1 Button Momentary and 1K Potentiometer
2K	2 Button Momentary and 5K Potentiometer
3K	3 Button Momentary and 10K Potentiometer
4K	4 Button Momentary and 25K Potentiometer
N	Blank

#### Cable Termination

Stock Code	Description
BG	Single 3/8" BSP Connection
EG	Central Connector
WG	WTG Connector
BD	35-50 Dinse On Power 3/8" BSP On Gas

#### US Cable Termination

Stock Code	Description
US	Lug On Power, 5/8" UNF RH Male On Gas
UN	Single 5/8" UNF RH Male
UD	35-95 Dinse On Power, 5/8" UNF RH Male On Gas

#### Cable Plug

Stock Code	Description
0	2 Pin Amphenol Plug
1	4 Pin Amphenol Plug
2	5 Pin Amphenol Plug
3	6 Pin Amphenol Plug
4	14 Pin Amphenol Plug
5	6 Pin Harting Plug
6	8 Pin Thermal Arc® Plug
7	3 Pin Tuchel Plug
8	9 Pin Tuchel Plug
9	5 Pin Tuchel Plug
10	12 Pin Bundy® Plug
11	7 Pin Migatronic® Plug
12	2 Pin XTI Inverter Plug
14	5 Pin XTI Inverter Plug

DIAGRAM FOR GUNS

**Standard Collet**

Stock Code	Description
A 10N21	Collet .020"/0.5mm Bore
10N22	Collet .040"/1.0mm Bore
10N23	Collet 1/16"/1.6mm Bore
10N24	Collet 3/32"/2.4mm Bore
10N25	Collet 1/8"/3.2mm Bore
54N20	Collet 5/32"/4.0mm Bore

**Standard Collet Body**

Stock Code	Description
B 10N29	Collet Body .020"/0.5mm Bore
10N30	Collet Body .040"/1.0mm Bore
10N31	Collet Body 1/16"/1.6mm Bore
10N32	Collet Body 3/32"/2.4mm Bore
10N28	Collet Body 1/8"/3.2mm Bore
406488	Collet Body 5/32"/4.0mm Bore

**Standard Ceramic Cup**

Stock Code	Description
C 10N50	Ceramic Cup 1/4"/6mm Bore
10N49	Ceramic Cup 5/16"/8mm Bore
10N48	Ceramic Cup 3/8"/10mm Bore
10N47	Ceramic Cup 7/16"/11mm Bore
10N46	Ceramic Cup 1/2"/13mm Bore
10N45	Ceramic Cup 5/8"/16mm Bore
10N44	Ceramic Cup 3/4"/19mm Bore

**Long Ceramic Cup**

Stock Code	Description
D 10N49L	Long Ceramic Cup 5/16"/8mm Bore
10N48L	Long Ceramic Cup 3/8"/10mm Bore
10N47L	Long Ceramic Cup 7/16"/11mm Bore

**Stubby Collet**

Stock Code	Description
E 10N21S	Stubby Collet .020"/0.5mm Bore
10N22S	Stubby Collet .040"/1.0mm Bore
10N23S	Stubby Collet 1/16"/1.6mm Bore
10N24S	Stubby Collet 3/32"/2.4mm Bore
10N25S	Stubby Collet 1/8"/3.2mm Bore

**Stubby Collet Body**

Stock Code	Description
F 17CB20	Stubby Collet Body .020"-1/8"/0.5-3.2mm Bore

**Stubby Ceramic Cup**

Stock Code	Description
G 13N08	Ceramic Cup 1/4"/6mm Bore
13N09	Ceramic Cup 5/16"/8mm Bore
13N10	Ceramic Cup 3/8"/10mm Bore
13N11	Ceramic Cup 7/16"/11mm Bore
13N12	Ceramic Cup 1/2"/13mm Bore
13N13	Ceramic Cup 5/8"/16mm Bore

**Standard Gas Lens Body**

Stock Code	Description
H 45V29	Gas Lens Body .020"/0.5mm Bore
45V24	Gas Lens Body .040"/1.0mm Bore
45V25	Gas Lens Body 1/16"/1.6mm Bore
45V26	Gas Lens Body 3/32"/2.4mm Bore
45V27	Gas Lens Body 1/8"/3.2mm Bore

**Standard Gas Lens Cup**

Stock Code	Description
I 54N17	Gas Lens Cup 5/16"/8mm Bore
54N16	Gas Lens Cup 3/8"/10mm Bore
54N15	Gas Lens Cup 7/16"/11mm Bore
54N14	Gas Lens Cup 1/2"/13mm Bore
54N19	Gas Lens Cup 1 1/16"/18mm Bore

**Long Gas Lens Cup**

Stock Code	Description
J 54N17L	Long Gas Lens Cup 5/16"/8mm Bore
54N16L	Long Gas Lens Cup 3/8"/10mm Bore
54N15L	Long Gas Lens Cup 7/16"/11mm Bore

**Large Diameter Gas Lens Body**

Stock Code	Description
K 45V116	Large Diameter Gas Lens Body 1/16"/1.6mm Bore
45V64	Large Diameter Gas Lens Body 3/32"/2.4mm Bore
995795	Large Diameter Gas Lens Body 1/8"/3.2mm Bore

**Large Diameter Gas Lens Cup**

Stock Code	Description
L 57N75	Large Diameter Gas Lens Cup 3/8"/10mm Bore
57N74	Large Diameter Gas Lens Cup 1/2"/13mm Bore
53N88	Large Diameter Gas Lens Cup 5/8"/16mm Bore
53N87	Large Diameter Gas Lens Cup 3/4"/19mm Bore

**Components**

Stock Code	Description
1 18CG	Cup Gasket
2 18CG20	Cup Gasket
3 54N01	Gas Lens Insulator (Use with 18CG)
4 54N63	Insulator Large Diameter Gas Lens (Use with 18CG)
5 PRO26FX	Torch Body Flexible
6 PRO26	Torch Body
7 98W18	Back Cap 'O' Ring
8 PRO57Y02	Pro-Grip® Back Cap Long
9 PRO57Y04	Pro-Grip® Back Cap Short
10 PRO1MS-10	Momentary Switch Kit (Fitted as standard)
11 PROSWL4	Switch Lead x 4m (12.5ft)
PROSWL8	Switch Lead x 8m (25ft)
12 PROH200	Pro-Grip® TIG Handle Large
13 PROSP	Screw Pack
14 PROKJ200	Knuckle Joint c/w Lock Nut
15 PROLC200-08	Leather Cover x .8m (2.6ft)
16 PROCO200-40	Complete Cover Assembly x 4m (12.5ft)
PROCO200-80	Complete Cover Assembly x 8m (25ft)
17 PRONC32	Neoprene Cover x 3.2m (10.5ft)
PRONC72	Neoprene Cover x 7.2m (23.6ft)
18 PROJK20	Jointing Repair Kit
19 7.131.012	Inverter Pulg

## §5.3 Spool Gun

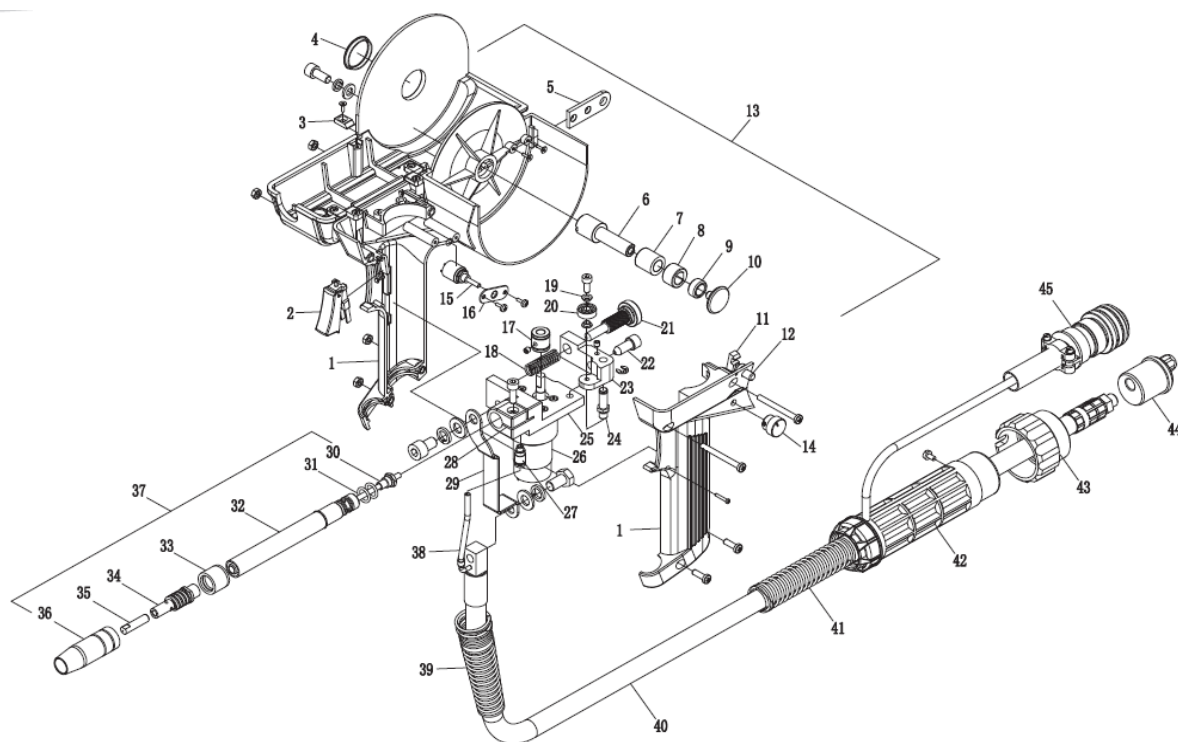

### Components

No.	Part Number	Description
1	LWH2101	Gun Handle
2	EJ0003	Trigger Switch
3	LWH2111	Block
4	LWH2112	Cover
5	LWH2116	Hanger Hook
6	LWT2015	Spool Shaft
7	LMT2014	Bushing Resistance Rubber
8	LWT2013	Location Bushing
9	LMT2012	Adjusting Nut
10	LWT2011	Locking Screw
11	LWH2113	Hook
12	LWH2114	Press Button
13	LWH2100	Handle Assembly(1-12)
14	LWH2115	WFS Control Knob
15	Q8110*	Potentiometer 10KΩ
	Q8105	Potentiometer 5KΩ
	Q8101	Potentiometer 1KΩ
16	LWI2011	Potentiometer Housing
17	LWZ2011*	Drive Roll 0.8/0.9
	LWZ2020	Drive Roll 1.0/1.2
18	LWZ2018	Press Arm Spring
19	LWZ2016	Bushing
20	LWZ2017	Bearing
21	LWZ2015	Press Arm Bolt
22	LWZ2014	Inlet Guide
23	LWZ2013	Press Arm

### Components

No.	Part Number	Description
24	LWZ2012	Press Arm Shaft
25	LWZ2019	Bracket
26	LZ2830*	Motor and Gear Box (30:1)
	LZ2820	Motor and Gear Box (20:1)
27	Q9104	Gas Connector
28	LWZ2000	Wire Feeder Assembly(17-27)
29	LWK2001	Conducting Bar
30	LWR11170	Liner Assembly
31	Q507618	O-Ring 7.65×1.78
32	LWF1111	Straight
33	EF1011	Insulator
34	LWD1101	Diffuser C/W Spring
35	EB1108*	Contact Tip 0.8mm M6×25 Ecu
	EB1109	Contact Tip 0.9mm M6×25 Ecu
	EB1110	Contact Tip 1.0mm M6×25 Ecu
36	EA1212	Nozzle 12mm
37	LWF11180	Gun Neck 180°
38	LWW2101	Internal Gas Hose
39	LWS2101	Front Spring Cable Support
40	LWL2140	Cable Assembly 4m
41	ES2201	Back Spring Cable Support
42	EH2201	Gun Plug Housing
43	EP2001	Gun Plug Nut
44	LWU2001*	Euro Gun Plug Without Control
	LTU2002	Euro Gun Plug
45	MV0010	10 Pin Connector

\* Denotes Standard Build

## §6 Welding Trouble Shooting

### §6.1 Troubleshooting

- Before the welding machines are dispatched from the factory, they have already been tested and calibrated accurately. **Do not change settings on the equipment!**
- Maintenance course must be operated carefully. If any wire becomes flexible or is misplaced, it maybe potential danger to user!
- Only professional maintenance staff that is authorized by manufacturer should service the machine!
- **Be sure to shut off the Main Input Power before doing any repair work on the welding machine and wait 5 minutes for capacitor voltage to decrease!**
- If there is any problem and there is no authorized professional maintenance personal on site, please contact local agent or the distributor!

If there are some simple troubles with the welding machine, you can consult the following Chart:

NO.	Troubles		Reasons	Solution
1	Turn ON power but the power light is not illuminated.		Switch damaged	Change it
			Fuse damaged	Change it
			Power cord damaged	Change it
2	After welding machine is over-heat, the fan doesn't work		Fan damaged	Change it
			The cable is loose	Screw the cable tight
3	Press the gun switch, no output shielded gas	No output gas when test gas	No gas in the gas cylinder	Change it
			Gas hose leaks gas	Change it
			Electromagnetic valve damaged	Change it
	Output gas when test gas	Control switch damaged	Repair the switch	
Control circuit damaged		Check the PCB		
4	Wire-feeder doesn't work	Wire reel doesn't work	Motor damaged	Check and change it
		Wire reel works	Control circuit damaged	Check the PCB
			The idler roll is loose or weld wire skids	Adjust tension screws

WELDING TROUBLR SHOOTING

			The drive roll doesn't fit with the diameter of weld wire	Change the roll
			Wire reel damaged	Change it
			Wire feed pipe is jammed	Repair or change it
			Tip is jammed because of splash	Repair or change it
5	No striking arc and no output voltage		Output cable is connected incorrectly or loosen	Screw it down or change it
			Control circuit damaged	Check the circuit
6	Welding stops, and alarm light is on		Machine has self-protection	Check over-voltage, over-current, over-temperature, lower-voltage and over-temperature, and solve it
7	Welding current is run away and can be not controlled		The potentiometer damaged	Check or change it
			The control circuit damaged	Check the circuit
8	The crater current can be not adjusted		The PCB damaged	Check it
9	No post-gas		The PCB damaged	Check it

## §6.2 MIG Welding - Trouble Shooting

The following chart addresses some of the common problems of MIG welding. In all cases of equipment malfunction, the manufacturer's recommendations should be strictly adhered to and followed.

NO.	Trouble	Possible Reason	Suggested Remedy
1	<b>Excessive Spatter</b>	Wire feed speed set too high	Select lower wire feed speed
		Voltage too high	Select a lower voltage setting
		Wrong polarity set	select the correct polarity for the wire being used - see machine setup guide
		Stick out too long	Bring the torch closer to the work
		Contaminated base metal	Remove materials like paint, grease, oil, and dirt, including mill scale from base metal
		Contaminated MIG wire	Use clean, dry, rust free wire. Do not lubricate the wire with oil, grease etc.
		Inadequate gas flow or too much gas flow	Check the gas is connected, check hoses, gas valve and torch are not restricted. Set the gas flow between 20-40 CFH (6-12 l/min) flow rate. Check hoses and fittings for leaks. Protect the welding zone from wind and drafts
2	<b>Porosity - small cavities or holes resulting from gas pockets in weld metal.</b>	Wrong gas	Check that the correct gas is being used
		Inadequate gas flow or too much gas flow	Check the gas is connected, check hoses, gas valve and torch are not restricted. Set the gas flow between 20-40 CFh (6-12 l/min) flow rate. Check hoses and fittings for leaks. Protect the welding zone from wind and drafts
		Moisture on the base metal	Remove all moisture from base metal before welding
		Contaminated base metal	Remove materials like paint, grease, oil, and dirt, including mill scale from base metal
		Contaminated MIG wire	Use clean, dry, rust free wire. Do not lubricate the wire.
		Gas nozzle clogged with spatter, worn or out of shape	Clean or replace the gas nozzle
		Missing or damaged gas diffuser	Replace the gas diffuser
		MIG torch euro connect O-ring missing or damaged	Check and replace the O-ring
3	<b>Wire stubbing</b>	Holding the torch too far away	Bring the torch closer to the work and

WELDING TROUBLE SHOOTING

	<b>during welding</b>		maintain stick out of 5~10mm
		Welding voltage set too low	Increase the voltage
		Wire Speed set too high	Decrease the wire feed speed
4	<b>Lack of Fusion – failure of weld metal to fuse completely.</b>	Contaminated base metal	Remove materials like paint, grease, oil, and dirt, including mill scale from base metal
		Not enough heat input	Select a higher voltage range and /or adjust the wire speed to suit
		Improper welding technique	Keep the arc at the leading edge of the weld pool. Gun angle to work should be between 5 & 15°. Direct the arc at the weld joint Adjust work angle or widen groove to access bottom during welding Momentarily hold arc on side walls if using weaving technique
5	<b>Excessive Penetration – weld metal melting through base metal</b>	Too much heat	Select a lower voltage range and /or adjust the wire speed to suit Increase travel speed
6	<b>Lack of Penetration – shallow fusion between weld metal and base metal</b>	Poor in incorrect joint preparation	Material too thick. Joint preparation and design needs to allow access to bottom of groove while maintaining proper welding wire extension and arc characteristics. Keep the arc at the leading edge of the weld pool and maintain the gun angle at 5 & 15° keeping the stick out between 5-10mm
		Not enough heat input	Select a higher voltage range and /or adjust the wire speed to suit reduce travel speed.
		Contaminated base metal	Remove materials like paint, grease, oil, and dirt, including mill scale from base metal

## §6.3 MIG Wire Feed - Trouble Shooting

The following chart addresses some of the common WIRE FEED problems during MIG welding. In all cases of equipment malfunction, the manufacturer's recommendations should be strictly adhered to and followed.

NO.	Trouble	Possible Reason	Suggested Remedy
1	<b>No wire feed</b>	Wrong mode selected	Check that the TIG/MMA/MIG selector switch set to MIG position
		Wrong torch selector switch	Check that the Wire Feeder / Spool Gun selector switch is set to Wire Feeder position for MIG welding and Spool Gun when using the Spool gun
2	<b>Inconsistent/ interrupted wire feed</b>	Adjusting wrong dial	Be sure to adjust the wire feed and voltage dials for MIG welding. The amperage dial is for MMA and TIG welding mode
		Wrong polarity selected	Select the correct polarity for the wire being used. (see machine setup guide)
		Incorrect wire speed setting	Adjust the wire feed speed
		Voltage setting incorrect	Adjust the voltage setting
		MIG torch lead too long	Small diameter wires and soft wires like aluminum don't feed well through long torch leads - replace the torch with a lesser length torch
		MIG torch lead kinked or too sharp angle being held	Remove the kink, reduce the angle or bend
		Contact tip worn, wrong size, wrong type	Replace the tip with correct size and type
		Liner worn or clogged (the most common causes of bad feeding)	Try to clear the liner by blowing out with compressed air as a temporary cure, it is recommended to replace the liner
		Wrong size liner	Install the correct size liner
		Blocked or worn inlet guide tube	Clear or replace the inlet guide tube
		Wire misaligned in drive roller groove	Locate the wire into the groove of the drive roller
		Incorrect drive roller size	Fit the correct size drive roller; 0.8mm wire requires 0.8mm roller.
		Wrong type of drive roller selected	Fit the correct type roller (e.g. knurled rollers needed for flux cored wires)
Worn drive rollers	Replace the drive rollers		
Drive roller pressure too high	Can flatten the wire electrode causing it to lodge in the contact tip - reduce the drive roller pressure		

WELDING TROUBLE SHOOTING

		Too much tension on wire spool hub	Reduce the spool hub brake tension
		Wire crossed over on the spool or tangled	Remove the spool untangle the wire or replace the wire
		Contaminated MIG wire	Use clean, dry, rust free wire. Do not lubricate the wire.

## §6.4 DC TIG Welding - Trouble Shooting

The following chart addresses some of the common problems of DC TIG welding. In all cases of equipment malfunction, the manufacturer’s recommendations should be strictly adhered to and followed.

NO.	Trouble	Possible Reason	Suggested Remedy
1	<b>Tungsten burning away quickly</b>	Incorrect Gas or No Gas	Use pure Argon. Check cylinder has gas, connected, turned on and torch valve is open
		Inadequate gas flow	Check the gas is connected, check hoses, gas valve and torch are not restricted.
		Back cap not fitted correctly	Make sure the torch back cap is fitted so that the O-ring is inside the torch body
		Torch connected to DC +	Connect the torch to the DC- output terminal
		Incorrect tungsten being used	Check and change the tungsten type if necessary
		Tungsten being oxidized after weld is finished	Keep shielding gas flowing 10–15 seconds after arc stoppage. 1 second for each 10amps of welding current.
2	<b>Contaminated tungsten</b>	Touching tungsten into the weld pool	Keep tungsten from contacting weld puddle. Raise the torch so that the tungsten is off the work piece 2 - 5mm
		Touching the filler wire to the tungsten	Keep the filler wire from touching the tungsten during welding, feed the filler wire into the leading edge of the weld pool in front of the tungsten
3	<b>Porosity - poor weld appearance and color</b>	Wrong gas/ poor gas flow/ gas leak	Gas is connected, valve ON, check hoses, gas valve and torch are not restricted. Set the gas flow between 20-40 CFH (6-12 l/min). Check hoses and fittings for leaks
		Contaminated base metal	Remove moisture and materials like paint, grease, oil, and dirt from base

WELDING TROUBLE SHOOTING

			metal
		Contaminated filler wire	Remove all grease, oil, or moisture from filler metal
		Incorrect filler wire	Check the filler wire and change if necessary
4	<b>Yellowish residue / smoke on the alumina nozzle &amp; discolored tungsten</b>	Incorrect Gas	Use pure Argon gas
		Inadequate gas flow	Set the gas flow between 20-40 CFH (10-20 l/min) flow rate
		Alumina gas nozzle too small	Increase the size of the alumina gas nozzle
5	<b>Unstable Arc during DC welding</b>	Torch connected to DC +	Connect the torch to the DC- output terminal
		Contaminated base metal	Remove materials like paint, grease, oil, and dirt, including mill scale from base metal.
		Tungsten is contaminated	Remove 10mm of contaminated tungsten and re grind the tungsten
		Arc length too long	Lower torch so that the tungsten is off of the work piece 2 - 5mm
6	<b>Arc wanders during DC welding</b>	Poor gas flow	Check and set the gas flow between 20-40 CFH flow rate
		Incorrect arc length	Lower torch so that the tungsten is off the work piece 2 - 5mm
		Tungsten incorrect or in poor condition	Check that correct type of tungsten is being used. Remove 10mm from the weld end of the tungsten and re sharpen rod.
		Poorly prepared tungsten	Grind marks should run lengthwise with tungsten, not circular. Use proper grinding method and wheel.
		Contaminated base metal or filler wire	Remove contaminating materials like paint, grease, oil, and dirt, including mill scale from base metal. Remove all grease and oil from filler metal
7	<b>Arc difficult to start or will not start DC welding</b>	Incorrect machine set up	Check machine set up is correct
		No gas, incorrect gas flow	Check the gas is connected and cylinder valve open, check hoses, gas valve and torch are not restricted. Set the gas flow between 20-40 CFH flow rate
		Incorrect tungsten size or type	Check and change the size and or the tungsten if required
		Loose connection	Check all connectors and tighten
		Earth clamp not connected to work	Connect the earth clamp directly to the work piece wherever possible

## §6.5 MMA Welding - Trouble Shooting

The following chart addresses some of the common problems of MMA welding. In all cases of equipment malfunction, the manufacturer's recommendations should be strictly adhered to and followed.

NO.	Trouble	Possible Reason	Suggested Remedy
1	<b>No arc</b>	Incomplete welding circuit	Check earth lead is connected. Check all cable connections.
		Wrong mode selected	Check the MMA selector switch is selected
		No power supply	Check that the machine is switched ON and has a power
2	<b>Porosity – small cavities or holes resulting from gas pockets in weld metal</b>	Arc length too long	Shorten the arc length
		Work piece dirty, contaminated or moisture	Remove moisture and materials like paint, grease, oil, and dirt, including mill scale from metal
		Damp electrodes	Use only dry electrodes
3	<b>Excessive Spatter</b>	Amperage too high	Decrease the amperage or choose a larger electrode
		Arc length too long	Shorten the arc length
4	<b>Weld sits on top, lack of fusion</b>	Insufficient heat input	Increase the amperage or choose a larger electrode
		Work piece dirty, contaminated or moisture	Remove moisture and materials like paint, grease, oil, and dirt, including mill scale from metal
		Poor welding technique	Use the correct welding technique or seek assistance for the correct technique
5	<b>Lack of penetration</b>	Insufficient heat input	Increase the amperage or choose a larger electrode
		Poor welding technique	Use the correct welding technique or seek assistance for the correct technique
		Poor joint preparation	Check the joint design and fit up, make sure the material is not too thick for wire size.
6	<b>Excessive penetration - burn through</b>	Excessive heat input	Reduce the amperage or use a smaller electrode
		Incorrect travel speed	Try increasing the weld travel speed
7	<b>Uneven weld appearance</b>	Unsteady hand, wavering hand	Use two hands where possible to steady up, practice your technique
8	<b>Distortion –</b>	Excessive heat input	Reduce the amperage or use a

WELDING TROUBLR SHOOTING

	<b>movement of base metal during welding</b>		smaller electrode
		Poor welding technique	Use the correct welding technique or seek assistance for the correct technique
		Poor joint preparation and or joint design	Check the joint design and fit up, make sure the material is not too thick. Seek assistance for the correct joint design and fit up
9	<b>Electrode welds with different or unusual arc characteristic</b>	Incorrect polarity	Change the polarity, check the electrode manufacturer for correct polarity

## §7 Maintenance & Troubleshooting

### §7.1 Maintenance

The operator must understand the maintenance procedure of inverter welding machine and carry on simple examinations, cleanings and inspections. Do your best to protect the machine from contamination environment and leaving unit ON when not in use to lengthen service life of inverter arc welding machine. Inverter machines have transistors that are cooled by aluminum heat sinks. When the power supply is ON, the cooling fan brings dirt & dust into the machine covering the heat sinks and reducing cooling capacity over time.

- **Warning: For safety while maintaining the machine, please shut off the main input power and wait for 5 minutes, until capacitors voltage drops to safe voltage 36V!**

Date	Maintenance items
Daily examination	<p>Observe that the knobs and switches in the front and at the back of arc welding machine are flexible and put correctly in place. If any knob has not been put correctly in place, please correct. If you can't correct or fix the knob, please replace immediately.</p> <p>If any switch is not flexible or it can't be put correctly in place, please replace immediately! Please get in touch with maintenance service department if there are no accessories.</p> <p>After turn-on power, watch/listen if the arc-welding machine has shaking, whistle calling or peculiar smell. If there is one of the above problems, find out the reason and clear it. If you can't find out the reason, please contact your local service repair station or distributor/Agent.</p> <p>Observe that the display value of LED is intact. If the display number is not intact, please replace the damaged LED. If it still doesn't work, please maintain or replace the display PCB.</p> <p>Observe that the min./max.Values on LED agree with the set value. If there is any difference and it has affected the normal welding results, please adjust it.</p> <p>Check whether the fan is damaged and whether it is normal to rotate or control. If the fan is damaged, please change immediately. If the fan does not rotate but it starts when blades are rotated in direction of fan, the start capacity should be replaced.</p> <p>Observe whether the fast connector is loose or overheated. If the arc-welding</p>

MAINTENANCE & TROUBLESHOOTING

	<p>machine has the above problems, it should be fastened or changed.</p> <p>Observe whether the current output cable is damaged. If it is damaged, it should be insulated or changed.</p>
Monthly examination	<p>Using the dry compressed air to clear the inside of arc welding machine. Especially for clearing up the dusts on aluminium heat-sinks, inductors, IGBT modules, fast recover diodes, PCB's, etc.</p> <p>Check the screws and bolts in the machine. If any are loose, please tighten.</p> <p>Check all torches, earth clamp and hose connections to insure they are securely in place. Loose connections can cause major failures.</p>
Quarter-yearly examination	<p>Check whether the actual current accords with the displaying value. If they did not accord, they should be regulated. The actual welding current value can be measured by and adjusted by plier-type ampere meter.</p>
Yearly examination	<p>Measure the insulating impedance among the main circuit, PCB and case, if it below <math>1M\Omega</math>, insulation is thought to be damaged and needs to be changed to strengthen insulation.</p>

## §7.2 List of Error Codes



Error Type	Code	Description
Thermal relay	E01	Over-heating (1st thermal relay)
	E02	Over-heating (2nd thermal relay)
	E03	Over-heating (3rd thermal relay)
	E04	Over-heating (4th thermal relay)
	E09	Over-heating (Program default)
Welding machine	E10	Phase loss
	E11	N/A
	E12	No gas
	E13	Under voltage
	E14	Over voltage
	E15	Over current
	E16	Wire feeder over load
Switch	E20	Button fault on operating panel when switch on the machine
	E21	Other faults on operating panel when switch on the machine
	E22	Torch fault when switch on the machine
	E23	Torch fault during normal working process
Accessory	E30	Cutting torch disconnection
	E31	N/A
Communication	E40	Connection problem between wire feeder and power source
	E41	Communication error

### §7.3 Electrical Schematic Drawing

